

BALOGH



# BIET-170/\*\* EtherNet Control Interface

**RFID Control Interface**

**Industrial Product Range**



## Key For Tag Suffix

Suffix	Tag Series Description
X	OMX High Speed Industrial R/W Tag Series
E	GIE Industrial R/W Enhanced Speed Tag Series
A	OMA Industrial R/W Tag Series
F	OF Read-Only 7 Byte Industrial Tag Series
L	OLR Long Range 2 Byte Read-Only Industrial Tag
P	OP Light Industrial R/W Tag Series
FC	TAF High Speed R/W Light Industrial Tag Series
IC	TAI Light Industrial R/W Tag Series

## Ordering Information

When assembling your part number, please include the corresponding tag suffix.

**Example:** BIET/XX. - OMX High Speed Industrial R/W Tag Series. (Cables and Connectors Sold Separately)

## Characteristics

The Balogh BIET meets the needs required for today's network flexibility. It can communicate using Ethernet/IP<sup>®</sup>, TCP/IP, and MODBUS TCP/IP protocols. Connects via Ethernet link at fixed 10/100 or auto-negotiate. Each BIET has dual channel capability, and each functions independently and simultaneously. Small footprint provides ease of mounting (171mm x 130mm x 78mm). With an IP-65 rated metallic enclosure and quick connect wiring, it provides field mounting, durability, and reduces wiring costs.

### Features:

- Automatic Self Test on Power up
- Status LED's
- IP 65 Rated
- Configuration via RS-232 serial link by PC in Hyper-Terminal mode.
- Dip switch selectable protocols
- Configuration via HTML

## Installation Information/Cable Pin Outs

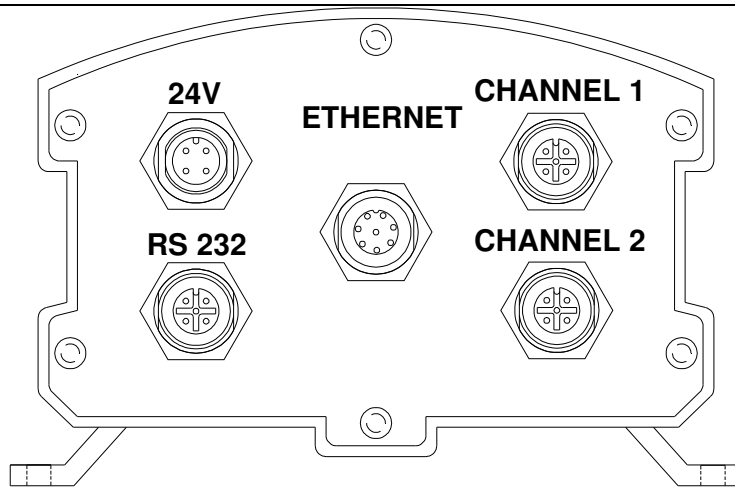

COLOR CODE REFERS TO ONLY BALOGH CABLING

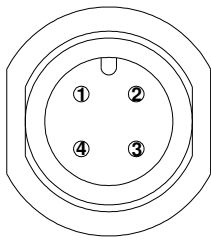

- 1 - +24VDC POWER (BROWN-V)
- 2 - NOT USED
- 3 - NOT USED
- 4 - 0VDC (BLACK-O)

**Power: 24 VDC**

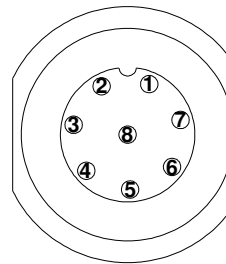

- 1 - LIGHT BLUE
- 2 - LIGHT BROWN
- 3 - BROWN
- 4 - ORANGE (-TX)
- 5 - LIGHT GREEN (+RX)
- 6 - WHITE (+TX)
- 7 - BLUE
- 8 - GREEN (-RX)

**Ethernet**

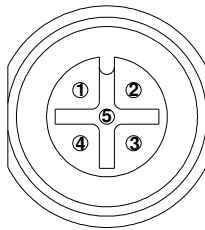

- 1 - +24VDC POWER (BROWN-V)
- 2 - INPUT (WHITE-S)
- 3 - OUTPUT (BLUE-E)
- 4 - 0VDC (BLACK-O)
- 5 - SHIELD

**Transceiver Channel 1&2**

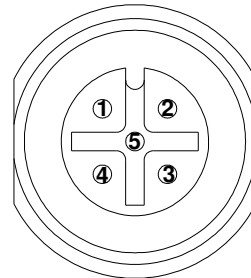

- 1 - NOT USED
- 2 - RX
- 3 - TX
- 4 - SIGNAL GROUND
- 5 - NOT USED

**RS-232**

## Cabling And Accessories (SOLD SEPERATELY)

Power Cable - SEF/ST/\*\*

Standard Cable Lengths are 2, 5m, 25, 50, 75, 100ft

Network Cable - BM12 RJ45/\*\* (LENGTHS ARE IN METERS)

Standard Cable Lengths are 1, 3, 5, 10

Transceiver Cable – MF/EXT/\*\* (LENGTHS ARE IN METERS)

Standard Cable Lengths are 2, 5, 10, 15, 20, 25, 30, 35

Configuration Cable - BIET FCB/\*\*

Standard Cable Length is 2m

\*\* Indicates Cable Length Please Contact Balogh for other cable lengths.

**Only Hand Tighten Cables Correct**

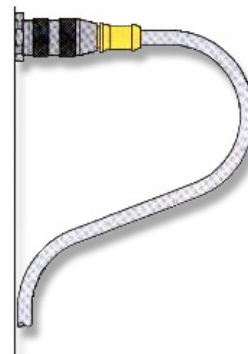

**Incorrect**

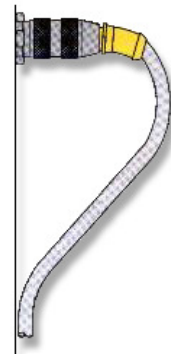

**Bend radius 3 x cable diameter**

## Technical Information

- 2 Transceiver Channels
- 1 M12 EtherNet Connection
- Operating Temperature 0° to 55° C
- Weight - 1200 Grams
- Requires Regulated 24 VDC (± 1%)
- Consumes 160 mA of power (without transceivers); 360 mA (with 2 transceivers)

See manual for power supply specifications.

Protocol	Dip Switch			
	1	2	3	4
<b>EtherNetIP®</b>	OFF	ON	OFF	OFF
<b>TCP/IP</b>	ON	OFF	OFF	OFF
<b>ModBus TCP/IP</b>	OFF	OFF	OFF	OFF
<b>IP RESET</b>	OFF	OFF	OFF	ON

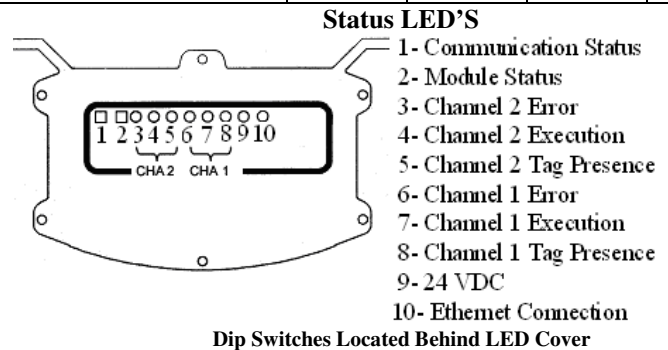

## FAQ

**Q: What are the BIET's default settings from the manufacturer?**

A: The BIET's IP Address from the manufacturer is **192.168.0.1**, the Subnet Mask is **255.255.255.0**, and the Gateway Address is **0.0.0.0**. The BIET's communications by default are set to auto-negotiate though the **EtherNet IP®** Protocol. at **57600 Kbaud**.

**Q: How do I access the BIET's HTML page?**

A: To obtain the BIET's HTML page, you'll need to open your web browser and type in the IP address of the BIET in the address bar.

**Q: What is the username and password when accessing the BIET through the HTML page?**

A: There isn't a username and the password is; **balogh**. (All Lowercase)

**Q: If the IP address of a BIET is unknown, how do I retrieve this information?**

A1: If running firmware revision 3.1 or later, dip switch 4 can be used to force the BIET back to its default setting.  
 A2: Another way to find the IP address is to connect to the BIET via RS-232, open Hyper Terminal, create a new Connection, and name it. Select the COM port being used, the bits per second ({baud rate} by default 57600 Kbaud), data bits (8), parity (none), stop bits (none), and flow control (none). Select ok and cycle power to the BIET, after it's initialization process the BIET's configuration page should be displayed. Continue by following the directions on screen.

**Q: How do I determine my firmware revision?**

A: Your firmware revision is displayed in the HTML page under the Current Parameters section.

**Q: If I change a setting in the HTML configuration page or within Hyper Terminal, when do the changes take place?**

A: Your changed setting DO NOT take place until you cycle power to the BIET.

**Q: What is the maximum Ethernet cable length I can use?**

A: 100m

**Q: What is the maximum transceiver cable length I can use?**

A: The maximum length of cabling that can be used for a transceiver varies among transceiver type. Please refer to the appropriate transceiver datasheet for cable length specifications.

# Dimensional Drawing

