

# BIDP 170

## DESCRIPTION PROFIBUS-DP SPECIFICATIONS

REF : M – BIDP 170 – 1.0-GB

### **BALOGH SA**

189, rue d'Aubervilliers - C.P. 97 75886 PARIS Cedex 18 – France ■ Tél : 33 (0)1 44 65 65 00  
■ Fax : 33 (0)1 44 65 65 10 ■ e-mail : [balogh@balogh-group.com](mailto:balogh@balogh-group.com) ■ web : [balogh-group.com](http://balogh-group.com)

---

*Public limited company with a capital of €800,000 - RCS B Paris 582 061 073*



## TABLE OF CONTENTS

Foreword

<b>1</b>	<b>GENERAL POINTS ABOUT IDENTIFICATION SYSTEMS .....</b>	<b>1</b>
<b>2</b>	<b>DESCRIPTION .....</b>	<b>2</b>
2.1	GENERAL POINTS.....	2
2.2	CONNECTOR FLANGE .....	2
2.3	VISUAL INDICATORS FLANGE .....	2
<b>3</b>	<b>INSTALLATION .....</b>	<b>4</b>
3.1	UNIT INSTALLATION .....	4
3.2	CONFIGURATION .....	5
3.3	CONNECTIONS.....	6
3.3.1	<i>Network link</i> .....	6
3.3.2	<i>R/W head connection</i> .....	7
3.3.3	<i>Power supply connection</i> .....	7
<b>4</b>	<b>OPERATIONAL PRINCIPLE .....</b>	<b>8</b>
4.1	BIDP INITIALISATION PHASES.....	8
4.2	DATA EXCHANGE MODES .....	8
<b>5</b>	<b>PROFIBUS FRAME STRUCTURE IN STANDARD MODE .....</b>	<b>10</b>
5.1	FRAME STRUCTURE.....	10
5.1.1	<i>Standard frame for master requests</i> .....	10
5.1.2	<i>BIDP standard response frame</i> .....	11
5.1.3	<i>Management of the frames sent by the master</i> .....	12
5.1.4	<i>Management of the response frames sent by the BIDP</i> .....	12
5.2	COMMAND DESCRIPTION .....	13
5.2.1	<i>Writing a block</i> .....	13
5.2.2	<i>Reading a block</i> .....	14
5.2.3	<i>Filling a zone (blanking)</i> .....	16
5.2.4	<i>Resetting the current operation</i> .....	17
5.2.5	<i>Discontinuous reading</i> .....	18
5.2.6	<i>Discontinuous writing</i> .....	20
5.2.7	<i>Turn on/off an R/W head</i> .....	21
5.2.8	<i>BIDP read flowchart</i> .....	22
5.2.9	<i>BIDP write flowchart</i> .....	24
<b>6</b>	<b>PROFIBUS-DP FRAMES IN SIMPLIFIED MODES .....</b>	<b>25</b>
6.1	DIRECT MODE .....	25
6.1.1	<i>Request (from user to BIDP)</i> .....	25
6.1.2	<i>Response (from BIDP to user)</i> .....	25
6.1.3	<i>Direct mode functions</i> .....	26
6.2	RECORDED MODE .....	28
6.2.1	<i>Frame headers</i> .....	28
6.2.2	<i>Access to BIDP memory by absolute addressing</i> .....	29
6.2.3	<i>Access to BIDP memory by relative addressing</i> .....	31
6.2.4	<i>Details of first parameter frames based upon operation</i> .....	37
6.3	MEMORY MAPPING .....	39
6.3.1	<i>General</i> .....	39
6.3.2	<i>System area</i> .....	40
6.3.3	<i>Command area</i> .....	40
6.3.4	<i>Response area</i> .....	40
6.3.5	<i>Data area</i> .....	40

APPENDIX 1: Tag addressing

APPENDIX 2: GSD file

APPENDIX 3: Connection accessories

## FOREWORD

### Purpose of this manual

After a review of the RF identification systems, this manual describes the BIDP 170 (Balogh ProfiBus-DP interface) and indicates how to install it.

Then it indicates the byte-based ProfiBus-DP frames (standard mode) and the word-based frames (simplified modes).

Documents dealing with the Profibus DP-V0 interfaces:

Product	PLC	Shell	Block	Purpose of the manual	Manual reference
BIDP170		self-contained		Description of BIDP 170 Profibus DP specifications	M -- BIDP170 – 1.0-GB
FS-S7E	S7 3xx or 4xx of Siemens	Step 7 ®	FC12	Implementation/use of block v5.3	M – FS-S7Ev5.3 – x.y-GB
			FB120	Implementation/use of block v6.0	M – FS-S7Ev6.0 – x.y-GB
FG-SD7	SD7 of GE-Fanuc	Cimplicity® ME	Balogh_ CNC	Implementation/use of block v1.1	M – FG-SD7v1.1 – x.y-GB

Performance and other features are specified in the BIDP associated data sheet.

### Reference of a manual

The generic reference of a manual is:

M - <product name + block version> - x.y-L where

M means Manual

x is the document version cue

y is a page index (local modification)

L is the used language.

### Updates

Version cue	Page index	Date	Description of updates
03-08-01	2	march 03	first edition
1	0	06/04/05	Addition: description of frames in standard mode; Paragraph Connection to R/W head revised.

### Symbology



Caution: material at risk



Conditions required for correct operation



Advice for better use



Note

### Note

The information contained in this manual is subject to modification without notice.

The BALOGH company may not be held responsible for the consequences of any errors or omissions nor for any misinterpretation of information.

Step 7 is a trademark of Siemens, Cimplicity is a trademark of GE-Fanuc.

# 1 GENERAL POINTS ABOUT IDENTIFICATION SYSTEMS

The BALOGH identification systems provide the association of information with a physical object. The data regarding this object are stored in an **electronic tag** that is applied to the object or its support.

These data can be remotely read and, in the case of R/W tags, can be changed using an appropriate **read/write head**.

The dialogue between electronic tag and head is managed with a **control board** (interface).

So the read or read-write system consists of two elements:

- an R/W head,
- a control board.

For the R/W head – tag dialogue, two technologies are available:

- inductive technology - electronic tags do not require any supply to communicate; they receive the energy required for operation from the electromagnetic field generated by the R/W head;
- IR technology - the tags are battery-operated for transmission and storage of data in memory.

The control board manages the operation of the transceiver as well as the dialogue with the electronic tag. It processes the data and provides the interface with the supervisor.

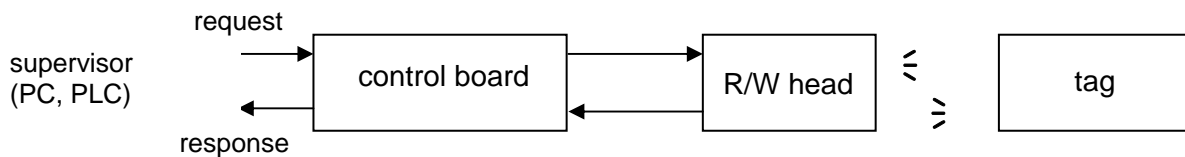

Based upon the user's choice and configuration of the application, the products of this range provide:

- parallel access to data,
- access to data by serial connection (RS 422/485 or RS 232) with adapted protocol or field network,
- an interface, programmable by user, allowing the management of local automatic control (sensors, actuators and processing).

A **monoblock** is a hardware combining interface and transceiver (R/W head) functions.

A **handheld** is portable hardware combining supervision and interface functions (the transmission function can be integrated or link-attached nearby).

## 2 DESCRIPTION

### 2.1 GENERAL POINTS

The BIDP 170 is the Balogh 1 or 2 channel RFID interface for the ProfiBus DP network.

The electronic card is mounted in an aluminium profile, sealed by two flanges, one carrying the connectors, the other the window for the observation of visual indicators (LEDs).

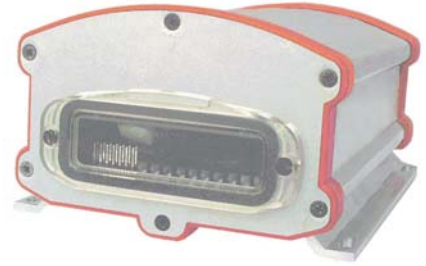

### 2.2 CONNECTOR FLANGE

The connector flange provides the connection of:

- a Y-tap on the fixed connector SUB-D 9 ("PROFIBUS"),
- an R/W head to each of the two M12 5-pin socket ("CHANNEL"),
- a 24VDC power receptacle on the supply fixed connector.

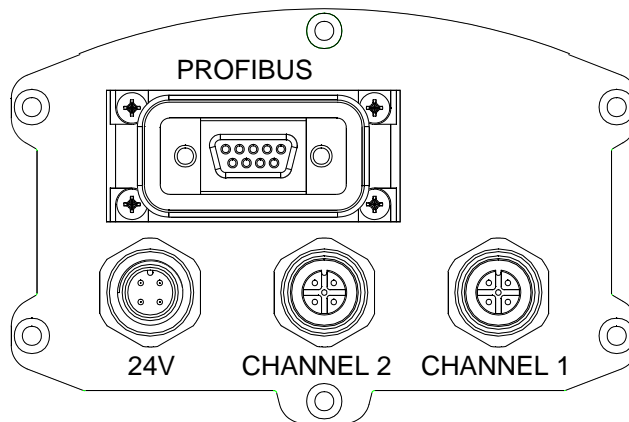

Each connector is equipped with a key (A-coding) that prevents any connection error.

### 2.3 VISUAL INDICATORS FLANGE

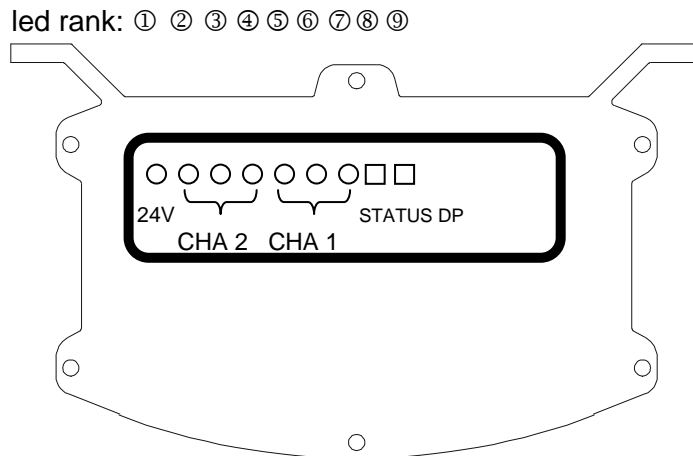

The visual indicators (LEDs) are located behind the window (from left to right):

- ① **LED 24 V:** voltage 24VDC
  - **green**, on when the unit is powered.

**THREE MONITORING LEDs** for each channel 2 ("channel 2"), and 1 ("channel 1"):

- ②/⑤ **Error LED ("ERR"):** tag or R/W head fault on the corresponding channel
  - red**, on when a fault is detected on the R/W head and/or tag;
  - e.g.: broken cable, disconnected R/W head, tag outside the transmission zone during an operation

③/⑥ **Presence LED ("PRE")**: tag present on corresponding channel  
**green**, on when a tag is in the transmission zone

④/⑦ **Execution LED ("EXE")**: operation in progress on the corresponding channel  
**green**, on when a command was received and is being executed

↳ When this led is lit, the two other leds are meaningless.

⑧ **A BI-COLOURED LED** monitoring the common electronics:

**Network Status LED ("status DP")**: LED for network BIDP status view

- **green fixed** indicates that the BIDP is ready and the PROFIBUS-DP® interface is initialized
- **green flashing** indicates that the PROFIBUS-DP® connection has not been established (configuration standby)
- **red fixed** indicates an initialization defect of the PROFIBUS-DP® interface or a defect during an exchange on the bus (blocking defect)
- **red flashing** indicates that the BIDP has been disconnected from the bus after initialization or the communication on the PROFIBUS-DP® network has been interrupted (non blocking defect).

↳ The last LED (⑨) is only used for maintenance.

### 3 INSTALLATION

#### 3.1 UNIT INSTALLATION

The BIDP 170 is housed in a field mount enclosure; vertical position is preferable (LED side upwards).  
The unit footprint is:

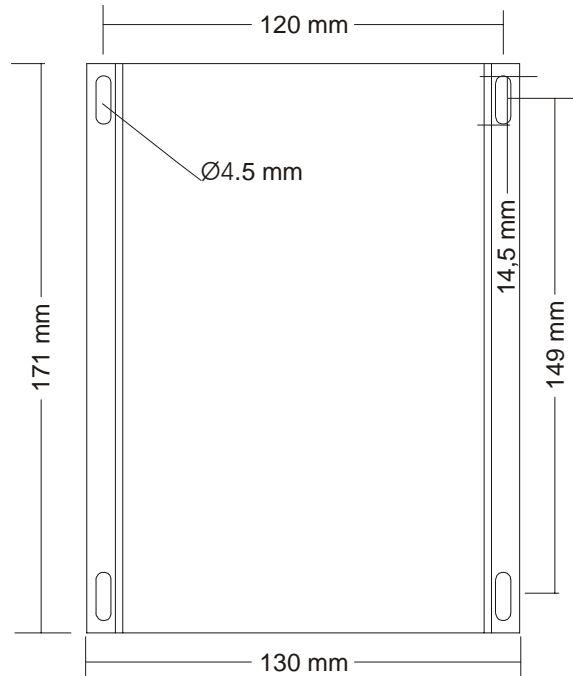

Fasten the BIDP using four screws



The horizontal installation, if chosen, exposes more the connectors to stress and shocks.

Provide a clearance of approximately 120 mm on the connector side:

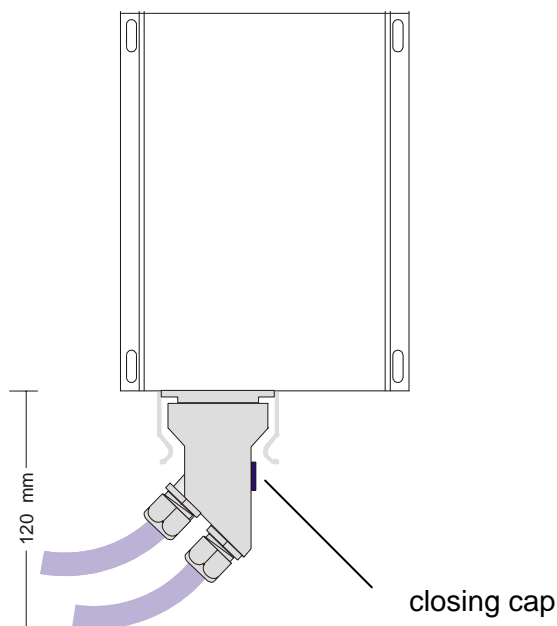



### 3.2 CONFIGURATION

Unscrew the two screws supporting the window and remove it in order to access the microswitch block.  
The microswitches # 1 to 7 define the station number (0 to 125):

n°st↓ sw→	7	6	5	4	3	2	1
0	OFF	OFF	OFF	OFF	OFF	OFF	OFF
1	OFF	OFF	OFF	OFF	OFF	OFF	ON
2	OFF	OFF	OFF	OFF	OFF	ON	OFF
.....	.....	.....	.....	.....	.....	.....	.....
125	ON	ON	ON	ON	ON	ON	ON

The microswitch # 8 defines the type de messaging protocol used to dialogue with the PLC:

mode↓ sw→	8	
<b>standard</b>	ON	refer to section 5
<b>simplified</b>	OFF	refer to section 6

 The microswitches setting is taken into account at power-on.

### 3.3 CONNECTIONS

Use the accessories listed in the data sheet "Connection accessories".

#### 3.3.1 NETWORK LINK

Using parts ⑤ to ⑩ assembly the Y-tap at an angle of 130°:

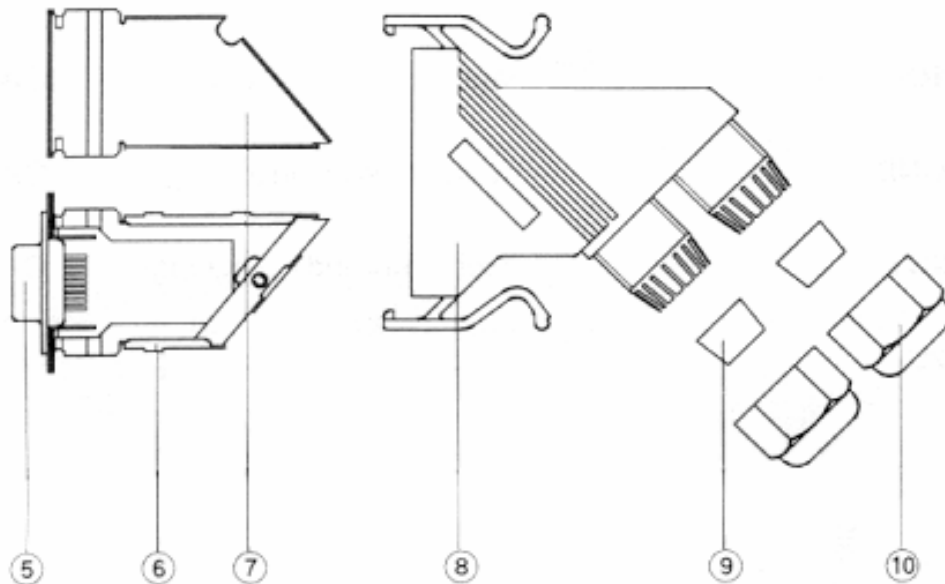

- ⑤ D-SUB contact insert
- ⑥ EMC inner sleeve, lower shell
- ⑦ EMC inner sleeve, upper shell
- ⑧ Sleeve housing
- ⑨ Cable gasket
- ⑩ Pressure nut

- slide the pressure nuts ⑩ and seals ⑨ over the cables (the seals pointing outwards), slide the cables into the sleeve housing ⑧; at the network end close the outgoing cable opening by inserting the cover cap (head outside) and tightening the pressure nut thoroughly,
- connect the cables internally:

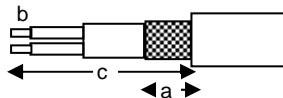

- remove the lower (resp. upper) cable sheath to length  $c = 25$  (resp.  $38$ ) mm
- cut the cable shield to length  $a = 11$  (resp.  $16$ ) mm
- strip the cores to length  $b = 5$  mm
- connect the cores at the terminals of the circuit attached to ⑤ in acc. with the table:

marking	RS485 signal	cable	wire color
1A	A	incoming	green
1B	B	incoming	red
2A	A	outgoing	green
2B	B	outgoing	red

- assembly the EMC inner sleeve:
  - position contact insert ⑤ in the lower shell ⑥ of the EMC inner sleeve ⑥ + ⑦,
  - screw cable shield with the clamping bar,
  - snap on upper shell ⑦ checking that the contact insert and the cables are correctly positioned,

- push the contact insert back into the sleeve housing and fix using self-tapping screws,
- push the seals ⑨ into the screw connections as far as they will go and tighten pressure nuts ⑩,
- open the closing cap (shown on page 4) and move the switch to the desired position using a suitable tool, in accordance with the table:

Position	Marking	Terminating, pull-up & pull-down resistors
to BIDP	ON	active
to network	OFF	not connected

- fasten the closing cap with due care to guarantee that it is tightly sealed.  
At last secure the sleeve housing on the fixed connector ("push-pull").

### 3.3.2 R/W HEAD CONNECTION

The shield connection depends on the used cable (the R/W head data sheets specify this cable):

- cables with overall shield: the overall shield must compulsorily be in contact over 360° to the metallic cable connector housing.
- cables with overall shield + shielded pairs: the overall shield must compulsorily be in contact over 360° to the metallic cable connector housing, while the pair shields are connected to pin 5 (optional);
- cables with shielded pairs, without overall shield: the pair shields must be connected to the metallic cable connector housing.

For this purpose several cordsets are proposed by Balogh:

- either an M12 double-ended cord,
- or an M12 single-ended (BIDP end) cord.

Refer to the appended data sheet Connection accessories.

### 3.3.3 POWER SUPPLY CONNECTION

Refer to the appended data sheet Connection accessories for the cordset specification.

Connector pin nr	Power supply	
	descr.	colour
1	+24VDC	brown
2, 3	nc	
4	0 V	blue

Refer to the BIDP data sheet for the voltage specifications.

## 4 OPERATIONAL PRINCIPLE

### 4.1 BIDP INITIALISATION PHASES

At the BIDP power-on:

- the PROFIBUS-DP® network-controller ASIC initialises and the DIP-microswitch positions are read thus defining the node address and type of supervisor messaging accepted,
- the supervisor sends the BIDP a parameter request,
- the supervisor sends the BIDP a configuration request specifying the number of bytes to be used for input & output transfer; if the configuration is accepted by the BIDP it then becomes ready to exchange data with the supervisor. The number of I/O bytes is configurable from 8 to 192 (8, 16, 32 then by steps of 32 up to 192); at power-on the BIDP is configured by default to 32 bytes for input and for output (recommended value).

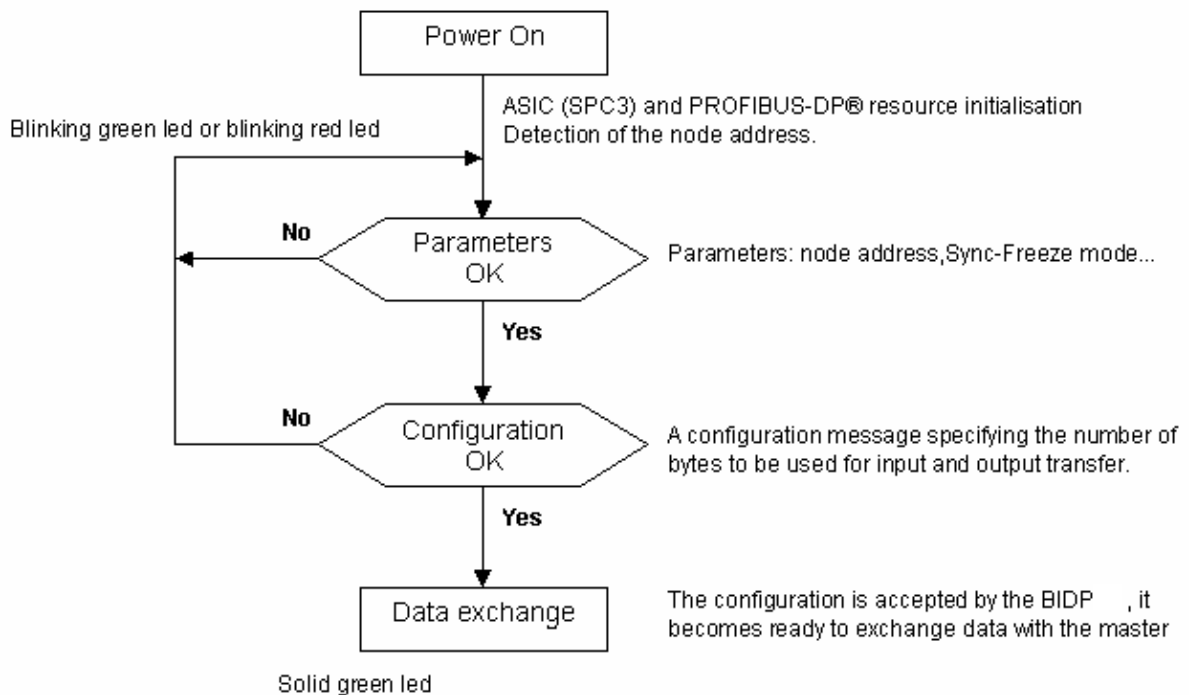

Figure – Initialisation flowchart based on Network status led

### 4.2 DATA EXCHANGE MODES

The supervisor cyclically polls each station of the Profibus DP network; the BIDP responds by sending a frame containing a status byte per transceiver channel (refer to the frame details).

This byte allows the determination of the BIDP status interface for each channel and informs the supervisor about a possible defect.

Interchanges use inputs/outputs the size of which can be configured: 8, 16, 32 bytes, then with a 32-byte step up to 192.

At start-up the default configuration - that is, 32 bytes, prevails.

The communication mode depends on the microswitch n°8 setting:

#### Standard mode

Compatible with BIDP 90 and BIDP 90DP.

This mode provides use of BALOGH functional blocks for various PLC types:

- refer to the manual M-FS-S7E when using a Siemens S7 PLC type 3xx or 4xx,
- refer to the manual M-FG-SD7 when using a GE Fanuc CNC (SD7 PLC).

## Simplified modes

The cyclic request may consist of a tag reading or writing command.

In order to help the user formulate this command, the BIDP provides two operating modes; the user can choose one of them based upon the number of bytes required by the operation:

- Direct mode

It is designed for simple reading/writing operations, which do not require more bytes than the size of working I/O (default 14 words for reading, 13 for writing).

The requests, the parameters or/and the data are placed at the supervisor outputs, the status and result of a reading are available at the inputs. As a result, when using this mode, it is not possible to simultaneously launch a request on both channels.

The operations in Direct mode have priority over the operations in the Recorded mode.

- Recorded mode

It is designed for more complex operations, such as readings/writings that require more bytes than the size of the I/O, for discontinuous readings/writings and repetitive commands.

The commands as well as the parameters and/or data must be **stored** in the BIDP memory. The commands are then **run whenever a tag shows**.

In this mode, it is possible to store a command for each of the two channels of BIDP.

The commands being stored, if the tags are present simultaneously, the BIDP **simultaneously** runs the operations of reading/writing **on the two channels**.

The uploading of operations and data reports (for reading) can be conducted as follows:

- full upload of a channel, then upload of the second,
- "interlaced" uploads (see examples of Recorded mode).

## 5 PROFIBUS FRAME STRUCTURE IN STANDARD MODE

### 5.1 FRAME STRUCTURE

#### 5.1.1 STANDARD FRAME FOR MASTER REQUESTS

Byte number	MSB				LSB			
	7	6	5	4	3	2	1	0
0	Cmd	Data	Command type		Ack	Channel	Cnt	
1	Tag address high byte							
2	Tag address low byte							
3	Data length high byte							
4	Data length low byte							
5	1 <sup>st</sup> Byte of data							
....	...							
31	27 <sup>th</sup> Byte of data							

#### Bit definition of "Protocol" byte (byte 0)

type of frame

Bit 7	Bit 6	
0	0	empty frame (meaningless)
1	0	<b>command and first-data frame</b>
		type of command
		Bit 5 Bit 4 Bit 3 :
		0 0 0 nop
		0 0 1 Writing to a tag
		0 1 0 Reading from a tag
		0 1 1 Discontinuous reading (7 zones and 28 bytes in total)
		1 0 0 Filling a tag with the same value
		1 0 1 Resetting the current operation
		1 1 0 Discontinuous writing (3 zones and 18 bytes in total)
		1 1 1 Setting an R/W head on standby
1	1	<b>extra data frame (for fragmented write)</b>
		Bit 5 Bit 4 Bit 3
		1 1 1 End of data frame transmission

**Bit 2 : Ack**

Before sending a command the master sets this bit to 0 then changes to 1 when the execution bit in the BALOGH status goes to 0 (execution request starts).

Bit 1 : **Channel**: defines the channel to which the command applies (0 = channel 1; 1 = channel 2).

Bit 0 : **mod. 2 fragmentation counter.**

5.1.2 BIDP STANDARD RESPONSE FRAME

Byte number	MSB				LSB			
	7	6	5	4	3	2	1	0
0	Type of frame		Repetition type of command *		0	0 or 1		Cnt
1	PROFIBUS ERROR CODE							
2	Balogh status channel #1							
3	Balogh status channel #2							
4	Not used							
....	....							
31	Not used							

\* = 1 1 1 if the frame is the last of a fragmented command

type of frame

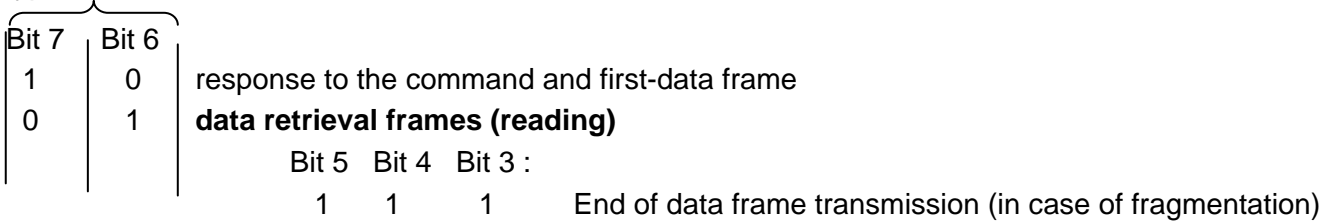

5.1.2.1 Profibus error code

- 0 : no error
- 1 : command unknown
- 2 : channel busy
- 3 : internal communication fault on the channel specified in the protocol byte; switch off the BIDP then switch on again to clear this fault.

5.1.2.2 BALOGH status byte

Definition of " BALOGH status byte":

B7	B6	B5	B4	B3 à B0
Execution	Battery fault	Tag presence	General fault	Error code
0	////////////////////	////////////////////	////////////////////	////////////////////
1			0	////////////////////
			1	Fault nibble

 Take the status into account ONLY IF bit 7 equals 1 (operation completed).

**Bit 7:** Execution Bit:

- 1 : operation completed with or without fault
- 0 : operation in progress

**Bit 6:** Battery low (for tags with a battery):

- 1 = battery low: to be replaced
- 0 = battery ok

**Bit 5:** Tag presence bit

- 1 = tag is present
- 0 = tag is not present

**Bit 4:** General error bit

- 1 = error (see error code)
- 0 = no error

**Bit 3 to 0:** Fault code (Valid if bit 7 = 1 or bit DONE\* = 1 and b4 = 1)

- 0001 = Invalid parameters: number of bytes is zero or over the maximum
- 0010 = Watch-dog error of the transceiver channel processor
- 0011 = RESET error of the transceiver channel processor
- 0101 = Internal communication error
- 1011 = Tag address error
- 1100 = R/W head error
- 1110 = Tag memory fault (impaired or not initialised)
- 1111 = Tag dialogue error

\* : relevant only for the standard mode using FS-S7E-v5.3 (refer to the document referenced M-FS-S7E-v5.3-x.y-GB).

### 5.1.3 MANAGEMENT OF THE FRAMES SENT BY THE MASTER

When the two channels are used, the master must process and transmit frames successively for channel #1 then for channel #2 in order to guarantee an equal processing time for each channel.

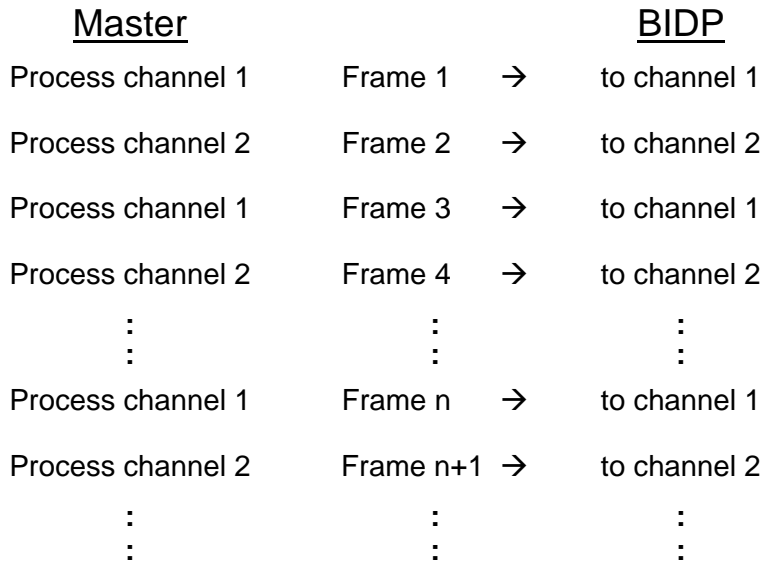

### 5.1.4 MANAGEMENT OF THE RESPONSE FRAMES SENT BY THE BIDP

When the two channels are functioning simultaneously, the BIDP transmits successively the response frames for channel #1 then those for channel #2.

The master's processing cycle and the BIDP's processing cycle being asynchronous, the reception of a frame sent by the BIDP for a channel must not automatically trigger the processing of this channel by the master; the master decides which channel must be processed based up the channel processed during the previous cycle.

**Example:**

The previous frame processed by the master is a frame sent by the BIDP for channel #2

The master receives a new frame for channel #2:

- the frame is not processed because during the previous cycle this channel has already been processed, it will be processed during the following cycle.
- the master processes channel #1.

The master receives a new frame for channel #2:

- channel #2 is processed because it was not during the previous cycle.



## 5.2 COMMAND DESCRIPTION

### 5.2.1 WRITING A BLOCK

#### 5.2.1.1 Command description

This command writes a data block to a dynamic code tag. The user can write up to 8 Kbytes of data per tag.

The number of frames required to write the data will depend on the size of the frames.

For ex.: if the configuration of 32 bytes is used then 273 frames are needed to transmit 8 Kbytes of data.

If more than one frame is needed to send all the data, the flag "data" must be set to "1" for all the frames of the command. For the last frame, bits 3, 4 and 5 are set to "1".

The operation may be achieved with or without a wait state: set bit 6 of the tag address to **1** if the operation is **with wait**.

#### 5.2.1.2 Initial frames

Master command:

Byte number	MSB				LSB			
	7	6	5	4	3	2	1	0
0	1	0	<b>0</b>	<b>0</b>	<b>1</b>	0	0 or 1	Cnt
1	Tag address high byte							
2	Tag address low byte							
3	Data length high byte							
4	Data length low byte							
5	1 <sup>st</sup> Byte of data to write							
...	...							
31	27 <sup>th</sup> Byte of data to write							

BIDP response:

Byte number	MSB				LSB			
	7	6	5	4	3	2	1	0
0	1	0	0	0	1	0	0 or 1	Cnt
1	PROFIBUS ERROR CODE							
2	Balogh Status channel #1							
3	Balogh Status channel #2							
4	Not used							
...	....							
31	Not used							

5.2.1.3 Fragmented data

Frames transmitted by the master:

Byte number	MSB				LSB			
	7	6	5	4	3	2	1	0
0	1	1	0*	0*	1*	Ack	0 or 1	Cnt
1	Number of data to follow (30 unless last frame)							
2	28 <sup>th</sup> byte of data to write							
3	29 <sup>th</sup> byte of data to write							
...	...							
31	57 <sup>th</sup> byte of data to write							

\* = 1 if the frame is the last frame of a fragmented command

BIDP response frame:

Byte number	MSB				LSB			
	7	6	5	4	3	2	1	0
0	1	1	0*	0*	1*	Ack	0 or 1	Cnt
1	PROFIBUS ERROR CODE							
2	Balogh Status channel #1							
3	Balogh Status channel #2							
4	Not used							
...	....							
31	Not used							

\* = 1 if the frame is the last frame of a fragmented command

5.2.2 READING A BLOCK

5.2.2.1 Command description

This command reads tag data from a dynamic code tag. This allows the user to read up to 8 Kbytes of data from a tag.

The number of frames required to read the data will depend on the size of the frames which will have been defined by the user.

For ex.: if the configuration is 32 bytes for I/O, then 273 frames are needed to obtain 8 Kbytes of data.

The BIDP returns no data until the command has been completely executed.

To obtain this data, the master does not need to send the command again (even if several frames are required). The master replies to each frame sent by the BIDP and increments the modulus 2 counter. The BIDP continues to send the same frame until the master acknowledges.

The frames sent by the BIDP contain the PROFIBUS-DP® status and a BALOGH status for each transceiver channel.

The data contained in these status bytes are important and should be monitored by the master.

The operation may be achieved with or without a wait state: set bit 6 of the tag address to **1** if the operation is **with wait**.

5.2.2.2 Frames

Master command:

Byte number	MSB					LSB		
	Cmd	Data	Command type			Ack	Channel	Cnt
0	1	0	0	1	0	0	0 or 1	cnt
1	Tag address high byte							
2	Tag address low byte							
3	Data length high byte							
4	Data length low byte							
5	Not used							
...	...							
31	Not used							

BIDP acknowledgment:

Byte number	MSB					LSB		
	Cmd	Data	Command type			Ack	Channel	Cnt
0	1	0	0	1	0	0	0 or 1	cnt
1	PROFIBUS ERROR CODE							
2	Balogh Status channel #1							
3	Balogh Status channel #2							
4	Not used							
...	....							
31	Not used							

Data retrieved by BIDP bound to the master:

Byte number	MSB					LSB		
	Cmd	Data	Command type			Ack	Channel	Cnt
0	0	1	0*	1*	0*	Ack	0 or 1	cnt
1	Number of data bytes to follow (28 unless last frame)							
2	Balogh Status channel #1							
3	Balogh Status channel #2							
4	1 <sup>st</sup> byte of data to read							
...	...							
31	28 <sup>th</sup> byte of data to read							

\* = 1 if the frame is the last frame of a fragmented command

Master acknowledgment:

Byte number	MSB					LSB		
	Cmd	Data	Command type			Ack	Channel	Cnt
0	0	1	0*	1*	0*	Ack	0 or 1	cnt
1	PROFIBUS ERROR CODE							
2	Not used							
...	...							
31	Not used							

\* = 1 if the frame is the last frame of a fragmented command

5.2.3 FILLING A ZONE (BLANKING)

5.2.3.1 Command description

This command fills a zone of the tag up to 8Kbytes with a given value.

The advantage of this command is that only one frame is sent.

The operation may be achieved with or without a wait state: set bit 6 of the tag address to 1 if the operation is with wait.

5.2.3.2 Frames

Master command:

Byte number	MSB					LSB		
	Cmd	Data	Command type			Ack	Channel	Cnt
0	1	0	1	0	0	0	0 or 1	cnt
1	Tag address high byte							
2	Tag address low byte							
3	Data length high byte							
4	Data length low byte							
5	Data to FILL TAG bytes with							
6	Not used							
....	...							
31	Not used							

BIDP response:

Byte number	MSB					LSB		
	Cmd	Data	Command type			Ack	Channel	Cnt
0	1	0	1	0	0	0	0 or 1	X
1	PROFIBUS ERROR CODE							
2	Balogh Status channel #1							
3	Balogh Status channel #2							
4	Not used							
...	....							
31	Not used							

## 5.2.4 RESETTING THE CURRENT OPERATION

### 5.2.4.1 Command description

This command deletes the current operation on a BIDP channel and operates without waiting. After execution of this command the BIDP is ready to receive new requests.

Ex: the operation to be deleted has a wait state; use the command to cancel the operation.

### 5.2.4.2 Frames

Master command:

Byte number	MSB				LSB			
	Cmd	Data	Command type		Ack	Channel	Cnt	
0	1	0	1	0	1	0	0 or 1	cnt
1	Not used							
...	...							
31	Not used							

BIDP response:

Byte number	MSB				LSB			
	Cmd	Data	Command type		Ack	Channel	Cnt	
0	1	0	1	0	1	0	0 or 1	X
1	PROFIBUS ERROR CODE							
2	Balogh Status channel #1							
3	Balogh Status channel #2							
4	Not used							
...	....							
31	Not used							

## 5.2.5 DISCONTINUOUS READING

### 5.2.5.1 Command description

This command reads a maximum of 7 zones located at different addresses for which the total of bytes read does not exceed 28 bytes. It is only valid for frames equal to or longer than 32 bytes.

The operation may be achieved with or without a wait state: set bit 6 of the tag address to 1 if the operation is with wait.

### 5.2.5.2 Frames

Master command:

Byte number	MSB					LSB		
	Cmd	Data	Command type			Ack	Channel	Cnt
0	1	0	0	1	1	0	0 or 1	cnt
1	1 <sup>st</sup> tag address high byte							
2	1 <sup>st</sup> tag address low byte							
3	1 <sup>st</sup> data length high byte							
4	1 <sup>st</sup> data length low byte							
5	2 <sup>st</sup> tag address high byte							
6	2 <sup>st</sup> tag address low byte							
7	2 <sup>st</sup> data length high byte							
8	2 <sup>st</sup> data length low byte							
9	3 <sup>st</sup> tag address high byte							
10	3 <sup>st</sup> tag address low byte							
11	3 <sup>st</sup> data length high byte							
12	3 <sup>st</sup> data length low byte							
13	4 <sup>st</sup> tag address high byte							
14	4 <sup>st</sup> tag address low byte							
15	4 <sup>st</sup> data length high byte							
16	4 <sup>st</sup> data length low byte							
17	5 <sup>st</sup> tag address high byte							
18	5 <sup>st</sup> tag address low byte							
19	5 <sup>st</sup> data length high byte							
20	5 <sup>st</sup> data length low byte							
21	6 <sup>st</sup> tag address high byte							
22	6 <sup>st</sup> tag address low byte							
23	6 <sup>st</sup> data length high byte							
24	6 <sup>st</sup> data length low byte							
25	7 <sup>st</sup> tag address high byte							
26	7 <sup>st</sup> tag address low byte							
27	7 <sup>st</sup> data length high byte							
28	7 <sup>st</sup> data length low byte							
29	Not used							
....	...							
31	Not used							

Note: when all the zones are not used, set the corresponding zone lengths to 0.

BIDP acknowledgment:

Byte number	MSB					LSB		
	Cmd	Data	Command type			Ack	Channel	Cnt
0	1	0	0	1	1	0	0 or 1	X
1	PROFIBUS ERROR CODE							
2	Balogh Status channel #1							
3	Balogh Status channel #2							
4	Not used							
...	....							
31	Not used							

Data retrieved by BIDP bound to the master:

Byte number	MSB					LSB		
	Cmd	Data	Command type			Ack	Channel	Cnt
0	0	1	0	1	1	Ack	0 or 1	cnt
1	Number of data bytes							
2	Balogh Status channel #1							
3	Balogh Status channel #2							
4	1 <sup>st</sup> byte of data to read							
...	...							
31	28 <sup>st</sup> byte of data to read							

Master acknowledgment:

Byte number	MSB					LSB		
	Cmd	Data	Command type			Ack	Channel	Cnt
0	0	1	0	1	1	Ack	0 or 1	X
1	PROFIBUS ERROR CODE							
2	Not used							
...	....							
31	Not used							

## 5.2.6 DISCONTINUOUS WRITING

### 5.2.6.1 Command description

This command writes to a maximum of 18 bytes shared between at most 3 zones located at different addresses in a tag.

This command is only valid for frame lengths equal to or greater than 32 bytes.

The operation may be achieved with or without a wait state: set bit 6 of the tag address to 1 if the operation is with wait.

### 5.2.6.2 Frames

Master command:

Byte number	MSB					LSB		
	Cmd	Data	Command type			Ack	Channel	Cnt
0	1	0	1	0	1	0	0 or 1	cnt
1	1 <sup>st</sup> tag address high byte							
2	1 <sup>st</sup> tag address low byte							
3	1 <sup>st</sup> data length high byte							
4	1 <sup>st</sup> data length low byte							
5	2 <sup>st</sup> tag address high byte							
6	2 <sup>st</sup> tag address low byte							
7	2 <sup>st</sup> data length high byte							
8	2 <sup>st</sup> data length low byte							
9	3 <sup>st</sup> tag address high byte							
10	3 <sup>st</sup> tag address low byte							
11	3 <sup>st</sup> data length high byte							
12	3 <sup>st</sup> data length low byte							
13	Data 1							
....	...							
30	Data 18							
31	Not used							

Note: when all the zones are not used, set the corresponding zone lengths to 0.

BIDP response:

Byte number	MSB					LSB		
	Cmd	Data	Command type			Ack	Channel	Cnt
0	1	0	1	1	0	0	0 or 1	X
1	PROFIBUS ERROR CODE							
2	Balogh Status channel #1							
3	Balogh Status channel #2							
4	Not used							
...	....							
31	Not used							



## 5.2.7 TURN ON/OFF AN R/W HEAD

### 5.2.7.1 Command description

This command powers on/off an R/W head. It operates without wait and may be useful when two heads are placed too close to each other, thus generating mutual interference.

### 5.2.7.2 Frames

Master command:

Byte number	MSB					LSB		
	Cmd	Data	Command type			Ack	Channel	Cnt
0	1	0	1	1	1	0	0 or 1	cnt
1	Val							
2	Val							
3	Not used							
....	...							
31	Not used							

Val = 0 turns off the head.

Val = FFh turns on the head.

 The command is valid if the bytes #1 and #2 contain the same value.

BIDP response:

Byte number	MSB					LSB		
	Cmd	Data	Command type			Ack	Channel	Cnt
0	1	0	1	1	1	0	0 or 1	X
1	PROFIBUS ERROR CODE							
2	Balogh Status channel #1							
3	Balogh Status channel #2							
4	Not used							
...	....							
31	Not used							

5.2.8 BIDP READ FLOWCHART

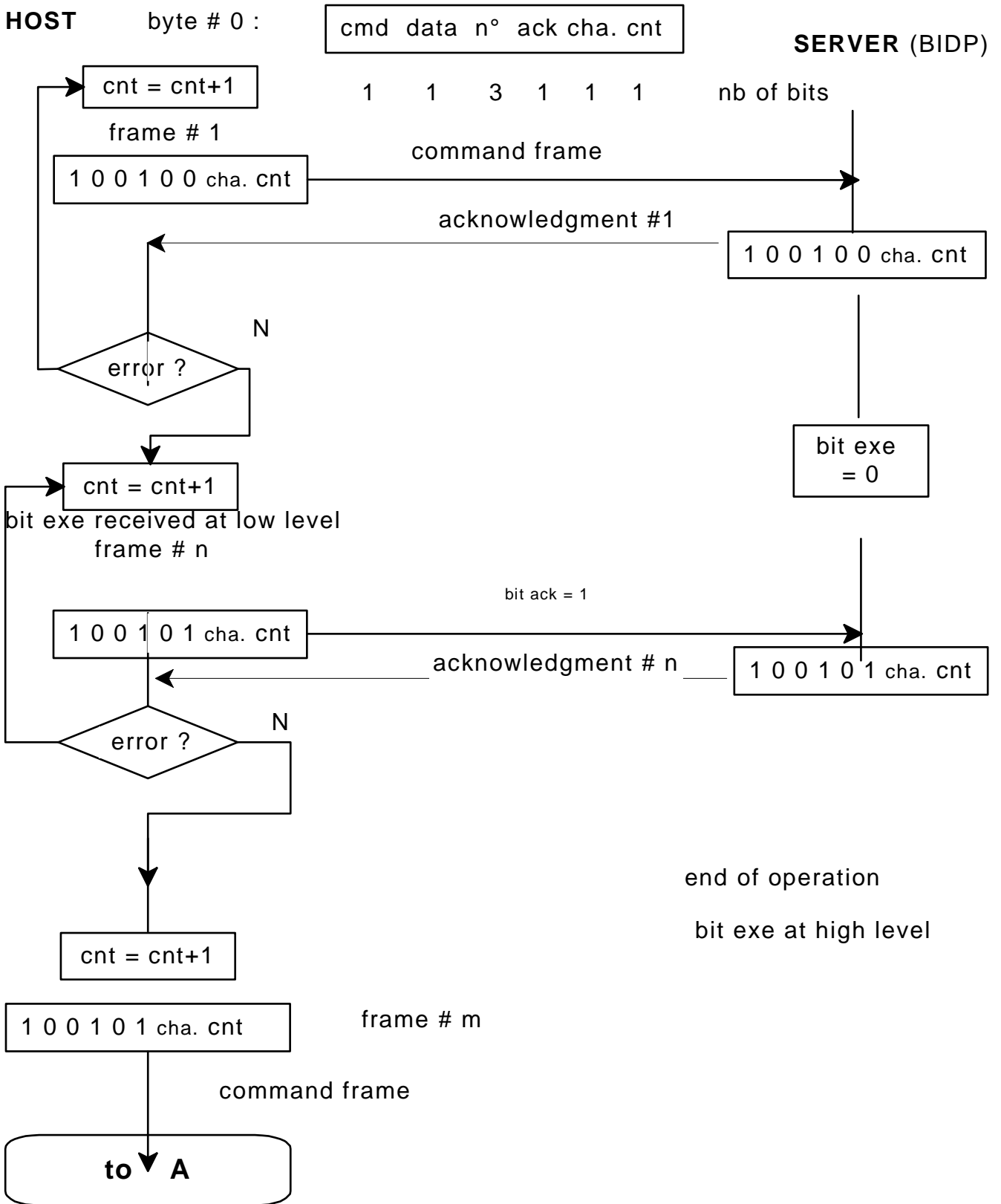

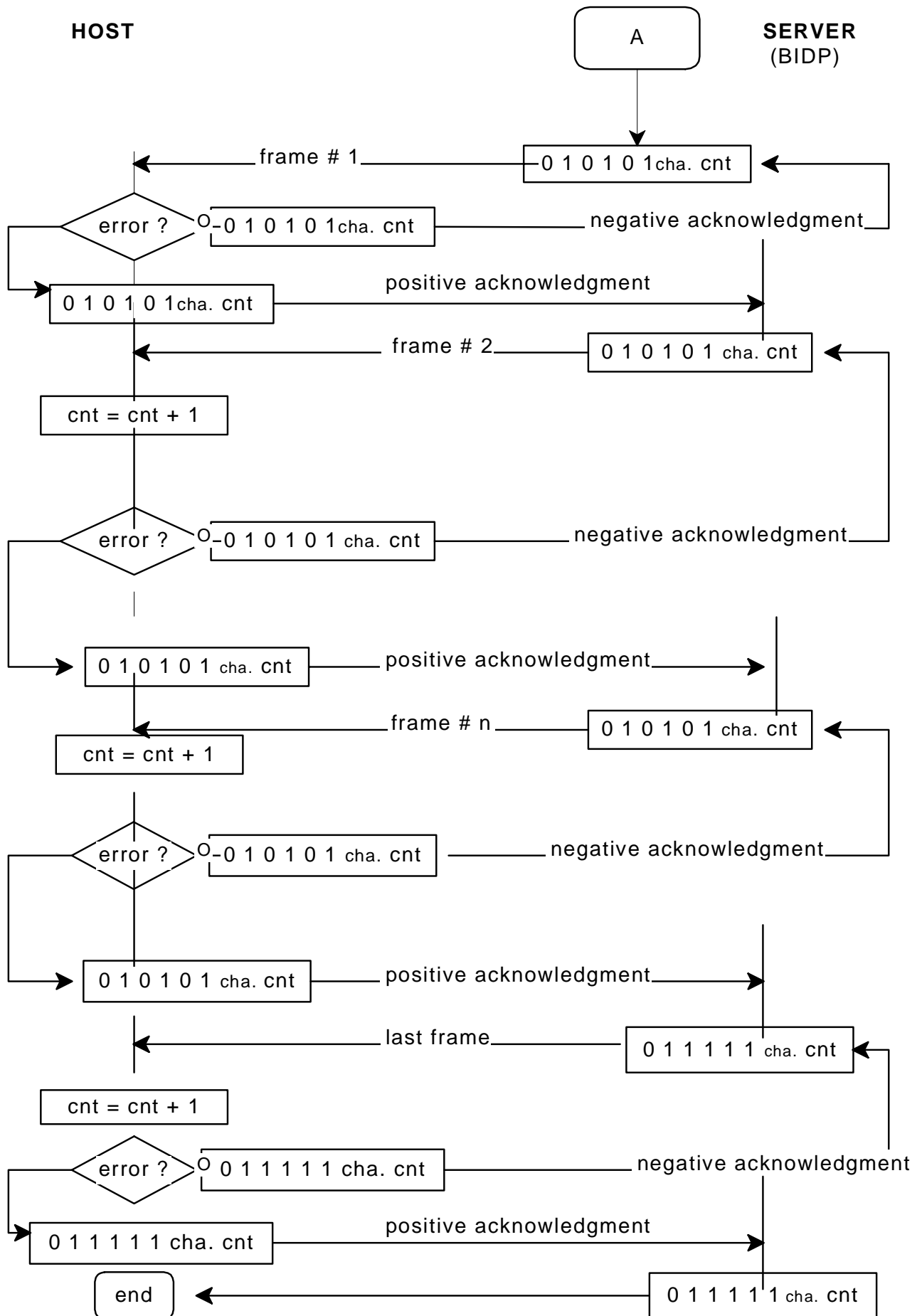

5.2.9 BIDP WRITE FLOWCHART

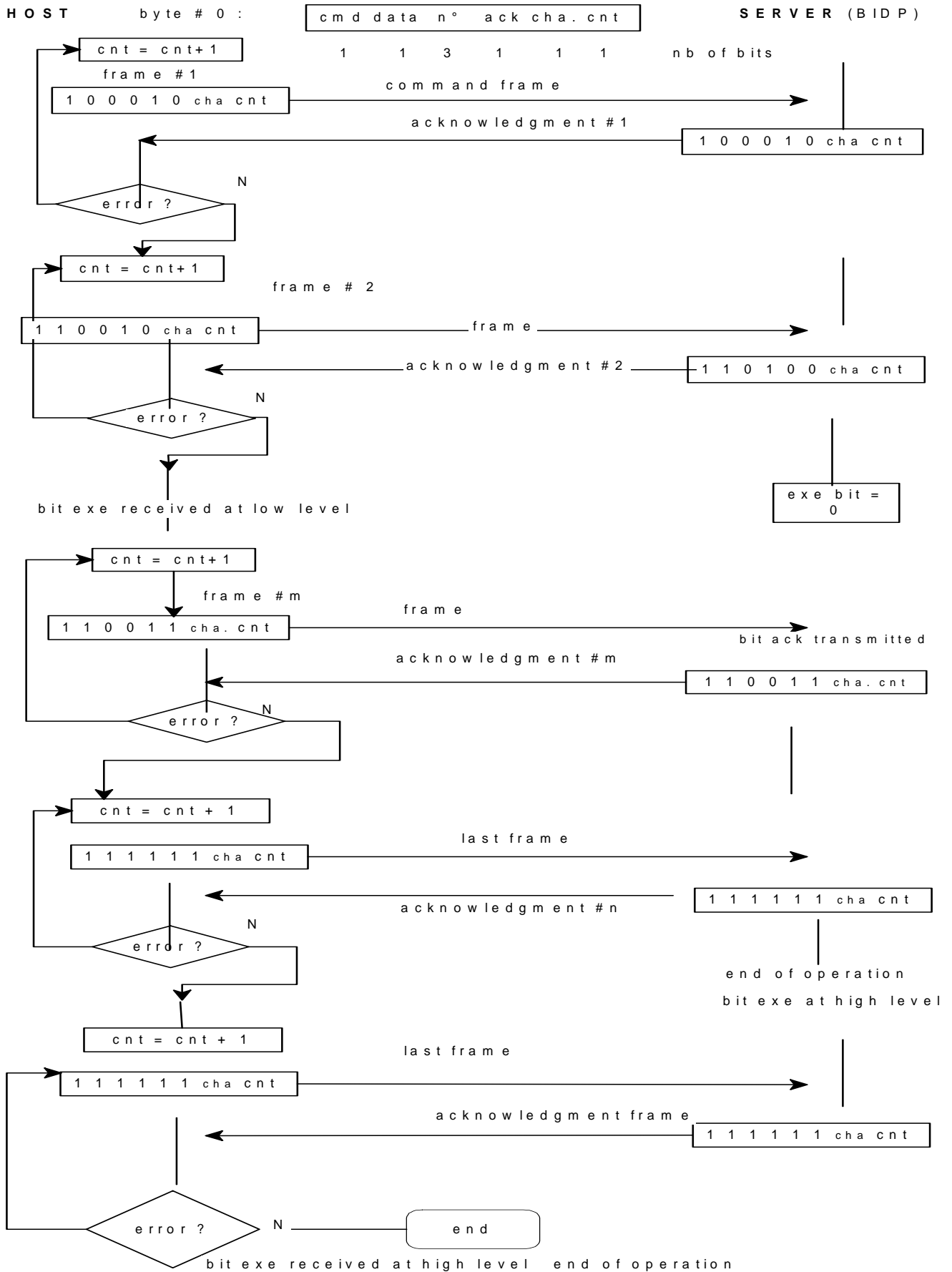

## 6 PROFIBUS-DP FRAMES IN SIMPLIFIED MODES

### 6.1 DIRECT MODE

This means Direct access to tag reading and writing.

#### 6.1.1 REQUEST (FROM MASTER TO BIDP)

only for internal use

**R:** block reading

**W:** block writing

**B:** blanking

**RESET:** reset being processed

**Inh:** channel activation/deactivation

**Copy:** tag copy channel 1 on channel 2

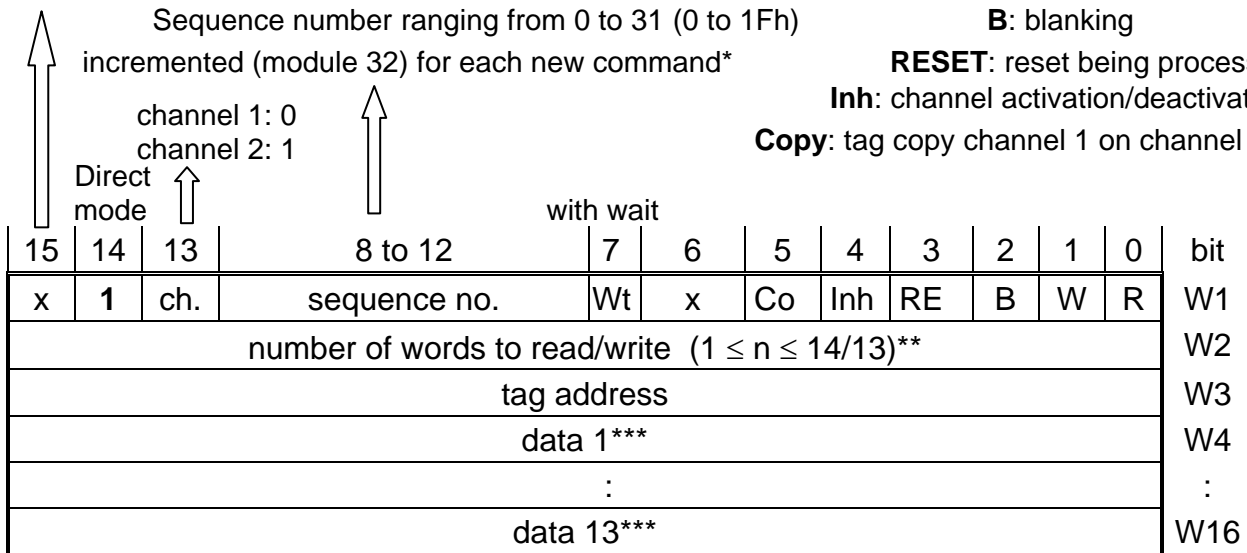

\* or for each repeated command

\*\* length  $\leq 7,500$  words for a blanking operation or Copy function (Copy = 1)

\*\*\* inquiry fields, if block writing

#### 6.1.2 Response (FROM BIDP TO MASTER)

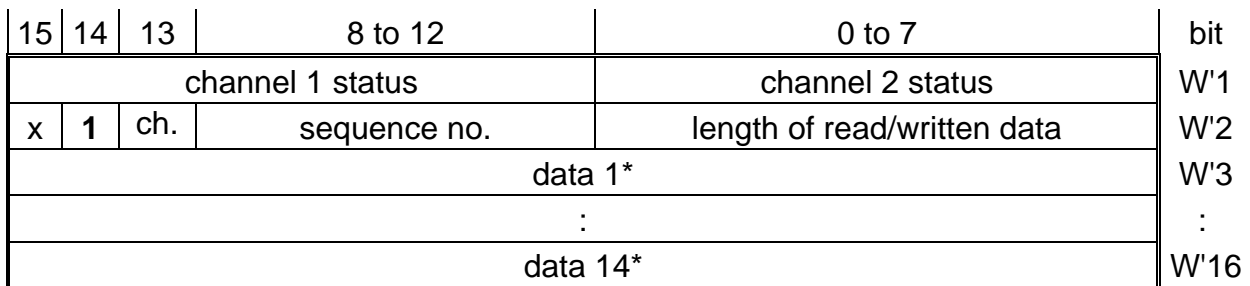

\* inquiry fields if block reading

The operation ends when the execution bit is at 1 AND the sequence number received is the same as the submitted number (as well as the channel index).

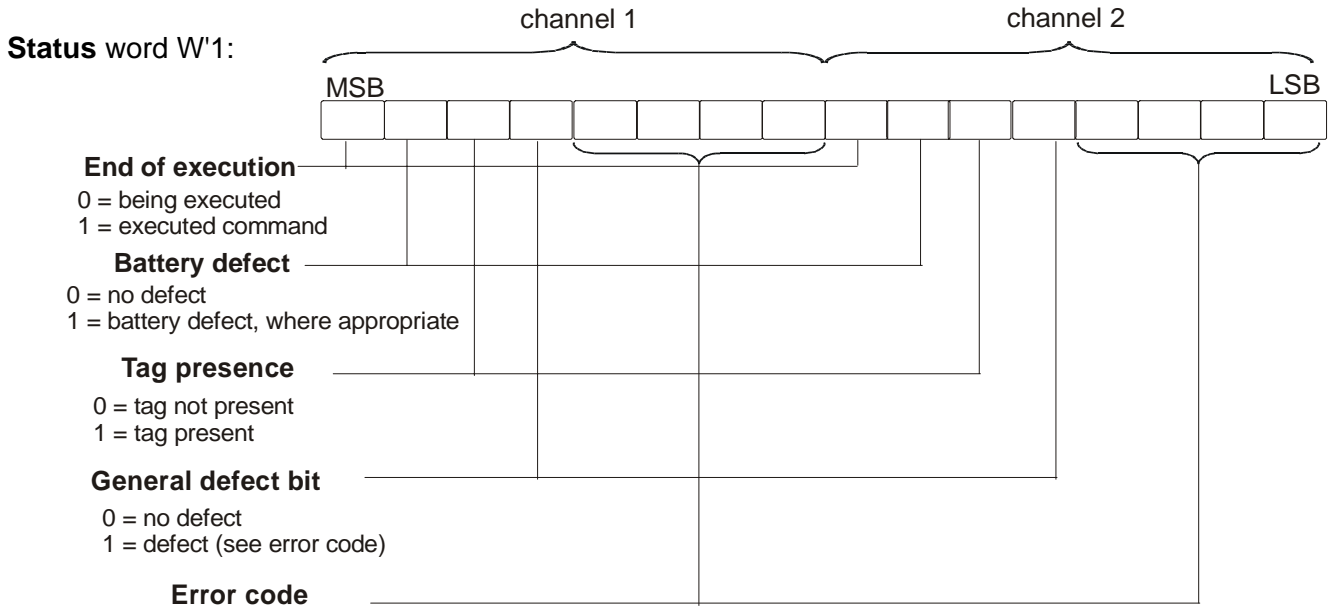

Error code:

code	signification
0001	invalid parameter or length (number of bytes = 0 or over the maximum)
0010	RESET of internal logic through watchdog
0011	RESET of internal logic
0101	internal dialogue defect
1100	R/W head defect
1101	tag addressing error
1110	tag memory fault
1111	dialogue impossible to finish

### 6.1.3 DIRECT MODE FUNCTIONS

#### 6.1.3.1 Tag block reading

e.g., channel 1 (bit 13 to 0), sequence no. 1, **reading without wait** (bit 0 to 1, bit 7 to 0) of 14 words on a tag OMX from address 0:

**Request:**

15	14	13	8 to 12	7	6	5	4	3	2	1	0	bit
0	1	0	0 0 0 0 1	0	0	0	0	0	0	0	1	W'1
14 (max.)												W'2
0												W'3

**Response:**

15	14	13	8 to 12	0 to 7	bit
channel 1 status = A0 h				channel 2 status	W'1
0	1	0	0 0 0 0 1	14	W'2
data 1					W'3
:					:
data 14					W'16

6.1.3.2 Tag block writing

e.g., channel 2 (bit 13 to 1), sequence no. 2, **writing with wait** (bit 0 to 0, bit 1 to 1, bit 7 to 1) of 13 words on a tag OMX from address 100 :

**Request:**

15	14	13	8 to 12	7	6	5	4	3	2	1	0	bit
0	1	1	0 0 0 1 0	1	0	0	0	0	0	1	0	W1
13 (max.)												W2
100												W3
first value												W4
:												:
last value												W16

**Response:**

15	14	13	8 to 12	0 to 7								bit
channel 1 status = A0 h				channel 2 status								W'1
0	1	1	0 0 0 1 0	13								W'2

6.1.3.3 Tag blanking

15	14	13	8 to 12	7	6	5	4	3	2	1	0	bit
x	1	ch	sequence no.	Att	0	0	0	0	1	0	0	W1
1 ≤ number of words to write ≤ 7,500												W2
tag address												W3
blanking data						x						W4

6.1.3.4 Reset

15	14	13	8 to 12	7	6	5	4	3	2	1	0	bit
x	1	ch	sequence no.	0	0	0	0	1	0	0	0	W1

6.1.3.5 Powering ON/OFF an R/W head

15	14	13	8 to 12	7	6	5	4	3	2	1	0	bit
x	1	ch	sequence no.	0	0	0	1	0	0	0	0	W1
Val						x						W2

Val = 0 : powering OFF an R/W head

Val = FFH : : powering ON an R/W head

6.1.3.6 Data copy

The operation consists of reading the data of a tag in channel 1 and writing on a tag in channel 2 :

15	14	13	8 to 12	7	6	5	4	3	2	1	0	bit
x	1	0	sequence no.	Att	0	1	0	0	0	0	0	W1
Number of words to copy(1 ≤ n ≤ N*)												W2
tag address channel 1 (source)												W3
tag address channel 2 (destination)												W4

The command is valid only if it is sent to channel 1. \*) N depends on the used tag size.

## 6.2 RECORDED MODE

### 6.2.1 FRAME HEADERS

#### Requests

The frames of all request types that the supervisor can address to the BIDP consist of a maximum of 16 words, if the size of the selected I/O is 32 (default value).

The header word (W1 word), which is essential, consists of:

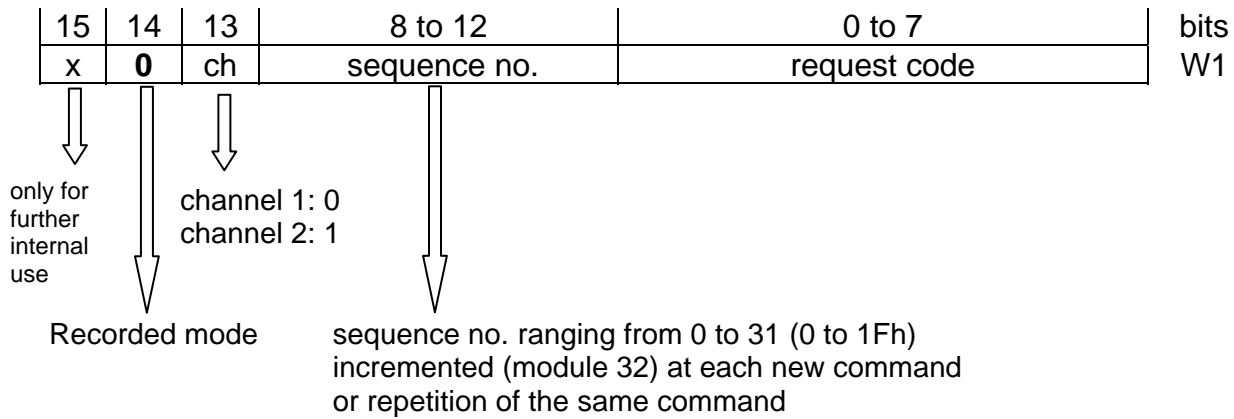

#### Responses

In response to the previous request, the BIDP sends a frame of maximum 16 words to the supervisor starting with a word providing the status of the two channels (W'1) and a Command word (W'2):

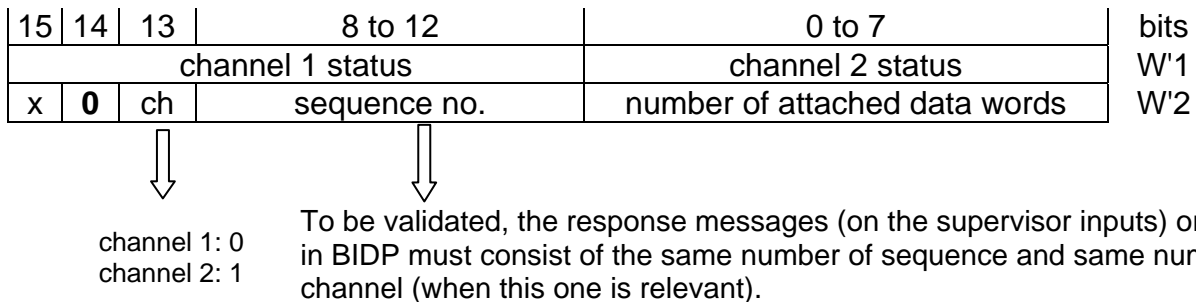



6.2.2 ACCESS TO BIDP MEMORY BY ABSOLUTE ADDRESSING

The memory address fields are provided in the Appendix; the words of the frame of the request received are provided in the Command area (and eventually System area).

6.2.2.1 Writing in the BIDP memory

Only a maximum of 13 words can be written by frame:

**Request**

x	0	x	sequence no.	<b>80h</b>	W1
number of words to write $\leq 13$					W2
address where 1 <sup>st</sup> word is written (System or Command area)					W3
data 1					W4
:					:
data 13					W16

NB: the channel number specified is not relevant (address indicates the channel)

**Response**

channel 1 status			channel 2 status		W'1
x	0	ch	sequence no.	response length = 1	W'2
Val					W'3

Val: 0000 h positive acknowledgment  
 -10100 h negative acknowledgment (problème dans la commande)  
 (invalid parameter)  
 0200 h negative acknowledgment (invalid command)

6.2.2.2 Reading of BIDP memory

**Request**

x	0	x	Sequence no.	<b>82h</b>	W1
number of words to read $\leq 7\ 500$					W2
address where the 1 <sup>st</sup> word must be read (System, Response, Data fields)					W3

NB: channel number is not relevant (the address indicates the channel)

If the number of words to read exceeds the size of the outputs, the supervisor must repeat its reading command by changing the sequence no. and by calculating the new absolute address every time.

Example:

Reading of tags sent on channel 1: number of words to read: 1, address: 8001 h

**Response**

channel 1 status			channel 2 status		W'1
x	0	ch	sequence no.	number of read words ( $1 \leq n \leq 14$ )	W'2
data 1 or error code					W'3
:					:
data 14					W'16

If the number of read words is null, the W'3 word includes the error code:

0100 h negative acknowledgment (invalid parameter)  
 0200 h negative acknowledgment (invalid command).

6.2.2.3 Application to tag access

For example, writing the tag address through a block of a certain length in order to be read:

**Writing parameters and data in the Command area**

x	0	x	sequence no.	80h	W1
2					W2
address where the block length should be written: 8006h/9D60 h					W3
block length ≤ 7,500					W4
block start address					W5

**Writing a Command word in the System field**

This means providing the nature of access operation: the only data is W4, "Command word" (for the previous example, only L is at 1 in the low byte):

x	0	x	sequence no.	80h	W1						
1					W2						
8002 h (channel 1) or 9D5C h (channel 2)					W3						
	0	rep		Comp	Co	dR	dW	B	W	R	W4
15	14	13	7 to 12	6	5	4	3	2	1	0	bit

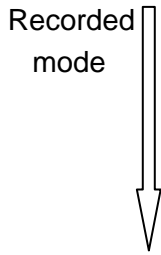

repetition bit:

- R: block reading
- W: block writing
- B: blanking
- dW: discontinuous writing
- dR: discontinuous reading
- Copy: tag copy channel 1 on channel 2
- Comp: comparison tags channels 1 and 2

If this bit is at 1, the operation is activated each time the tag shows (multiple command)

If this bit is at 0, the operation is performed only once (single command).

To stop a multiple command, launch a single command.

NB:

the dR and dW (discontinuous reading/writing) operations are specific for the Recorded mode,

- the Comp operation is not implemented yet.

**Result reading**

In this example, the words of the Data field are uploaded (up to the limit of 7,500 words):

x	0	x	sequence no.	82h	W1
number of words to read ≤ 7,500					W2
address where the 1 <sup>st</sup> word should be read: BAB7 h/D806 h					W3

6.2.3 ACCESS TO BIDP MEMORY BY RELATIVE ADDRESSING

6.2.3.1 Ecrit

When there are more than 13 parameter words to write (e.g., tag writing), instead use the following request, which as opposed to a 80h type request, provides the catenation of frames without recalculating the absolute address every time (the offset, number of words already written, is a relative word address).

**Request**

x	0	ch	sequence no.	<b>83h</b>	W1
number of words to write (in this frame)					W2
offset (0 if 1 <sup>st</sup> frame)					W3
data 1 (overall length ≤ 7,500 if 1 <sup>st</sup> frame)					W4
data 2 (tag address if 1 <sup>st</sup> frame)					W5
:					:
data n					W16

Offset: indicates the number of data sent in previous frames of the same request (for the second frame, it is 11).

As opposed to what it does for a 80h request, the supervisor does not specify that the length is written in 8006 h/9D60 h.

**Response**

channel 1 status			channel 2 status		W'1
x	0	ch	sequence no.	response length = 1	W'2
Val					W'3

- Val: 0000 h positive acknowledgment
- 0100 h negative acknowledgment (invalid parameter)
- 0200 h negative acknowledgment (invalid command)
- 0300 h negative acknowledgment (offset error)

6.2.3.2 Application to tag writing

6.2.3.2.1 Dynamic description

When the parameters (length, address, data) are stored in the BIDP Command area, the supervisor validates the operation by positioning the corresponding bit (and possibly the repetition bit) located in the Command word on the relevant channel and proceed with the writing of the Command word:

Supervisor	BIDP	Rep=	Exe =
Parameters and data writing	83h $\longrightarrow$ $\longrightarrow$		0
	$\longleftarrow$ Acknowledgment: Val = 0h		
Positioning ope and Rep bits		x	
Command word writing	80h $\longrightarrow$ $\longleftarrow$		A0h 80h
	Acknowledgment: Val = 0h Initializ. execution byte		
Repetition bit test			
if = 0, end		0	
if = 1, repetition		1	

**Recall:** it is possible to simultaneously launch a request on each channel.

6.2.3.2.2 Writing parameters and data in the Command area

e.g., writing a data block at a certain tag address:

First frame:

x	0	ch	sequence no. (1)	<b>83h</b>	W1
13					W2
0					W3
block length $\leq$ 7,500					W4
tag address					W5
data 1					W6
:					:
data 11					W16

**Response**

channel 1 status			channel 2 status		W'1
x	0	ch	sequence (1)	response length = 1	W'2
Val					W'3

Second frame:

x	0	ch	sequence no.(2)	<b>83h</b>	W1
number of words to write (in this frame)					W2
11					W3
data 12					W4
data 13					W5
:					:
data 24					W16

**Response**

channel 1 status				channel 2 status				W'1	
x	0	ch	sequence no. (2)		response length = 1				W'2
Val								W'3	

And so on until there are no data to process.

6.2.3.2.3 Writing a Command word in the System field

This request which consists of only one data is type 80h (for previous example, only W is at 1):

x	0	ch	sequence no. (3)		<b>80h</b>				W1					
1								W2						
8002 h (channel 1) or 9D5C h (channel 2)								W3						
	0	rep					Comp	Co	dR	dW	B	W	R	W4

Recorded mode

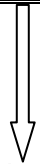

repetition bit:

- If this bit is at 1, the operation is activated every time the tag shows (multiple command)
- If this bit is at 0, the operation is performed only once (single command).

To stop a multiple command, launch a single command.

NB:

- the operations dR and dW (discontinuous reading/writing) are specific to the Recorded mode,
- the Comp operation is not implemented yet.

**Response**

channel 1 status				channel 2 status				W'1	
x	0	ch	sequence no.(3)		1				W'2
Val								W'3	

- Val: 0000 h positive acknowledgment  
 0100 h negative acknowledgment (invalid parameter)  
 0200 h negative acknowledgment (invalid command)

6.2.3.3 Application to tag reading

6.2.3.3.1 Dynamic description

Supervisor	BIDP	Rep=	Exe =
Parameter writing	80h →		0
	← Acknowledgment: Val = 0h		
Command word writing	80h →		A0h
	← Acknowledgment: Val = 0h		
Positioning of ope et Rep bits		x	
Data upload	81h →		
	← Data		
Repetition bit test			
if = 0, end		0	
if = 1, repetition		1	
	Initializ. Execution byte		80h

6.2.3.3.2 Request writing

**Writing parameters in the Command area**

As the supervisor has no data to send it can use a 80h request.

For example, writing the tag address of a block of a certain length to read:

x	0	x	sequence no.(1)	80h	W1
2					W2
address where the block length should be written: 8006h / 9D60 h					W3
block length ≤ 7,500					W4
block start address					W5

**Writing a Command word in the System field**

This provides the nature of access operation: the only data is W4, "Command word" (for the previous example, only R is at 1 in the low byte):

x	0	ch	sequence no (2)	80h	W1						
1					W2						
8002 h (channel 1) or 9D5C h (channel 2)					W3						
	0	rep		Comp	Co	dR	dW	B	W	R	W4
15	14	13	7 to 12	6	5	4	3	2	1	0	

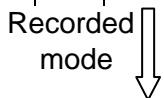

repetition bit:

R: block reading

dR: discontinuous reading

Copy: tag copy channel 1 on channel 2

Comp: comparison tags channels 1 and 2

- If this bit is at 1, the operation is activated every time the tag shows (multiple command)
- If this bit is at 0, the operation is performed only once (single command).

To stop a multiple command, launch a single command.

NB:

- the dR operation is specific to the Recorded mode,
- the Comp operation is not implemented yet.

6.2.3.3.3 Result reading

A request for tag reading provides the upload of data from the Data buffer field through a single word:

**Request**

To upload the reading data, without specifying an absolute address (as opposed to type 82h), the supervisor generates the following frame:

x	0	ch	sequence no.(3)	<b>81h</b>	W1
---	---	----	-----------------	------------	----

 If the number of words to read exceeds the size of I/O, the supervisor must repeat its reading command by changing the sequence no.; however, without changing the other parameters.

**Response**

channel 1 status				channel 2 status				W'1
x	0	ch	sequence no. (3)	Number of read words (1 ≤ n ≤ 13)				W'2
data offset								W'3
data 1								W'4
:								:
data 13								W'16

 It is not required to wait for the end of the reading operation to start the request of the BIDP in order to recover the data (if the data are not available, the acknowledgment of the outputs will not be validated (no sequence no. hit), l'automate pourra alors réitérer sa demande de lecture résultat; in this case, il y aura coïncidence des numéros de séquence et l'automate disposera des données contenues the low order of the word W'2 indicates the number of words available in the received frame).

 The supervisor devramust repeat its result reading command (changing the sequence no.) until having read all available data (the offset indicates the number of data already read).  
In the event that a problem occurs, the supervisor reads the defect code in the word W'2 in the Response field.

 It is possible to **interlace** the upload requests channel 1/channel 2 to take into account priorities; for example, reading two frames at the beginning of the tag on each channel alternately:

**1) operation recording:**

x	0	x	sequence no. (1)	<b>80h</b>				W1
2								W2
address where the block length should be written: 8006h								W3
block length = 26								W4
0								W5

x	0	x	sequence no. (2)	<b>80h</b>				W1
2								W2
address where the block length should be written: 9D60 h								W3
block length = 26								W4
0								W5

x	0	1	sequence no. (3)	<b>80h</b>				W1
1								W2
8002 h								W3
	0	0					0 0 0 0 0 0 1	W4

x	0	2	sequence no. (4)	<b>80h</b>	W1
1					W2
9D5C h					W3
	0	0		0 0 0 0 0 0 1	W4

**2) read data upload**

x	0	1	sequence no. (5)	<b>81h</b>	W1
---	---	---	------------------	------------	----

**Response**

channel 1 status			channel 2 status			W'1
x	0	1	sequence no. (5)	number of read words ( $1 \leq n \leq 13$ )		W'2
0						W'3
data 1						W'4
:						:
data 13						W'16

x	0	2	sequence no. (6)	<b>81h</b>	W1
---	---	---	------------------	------------	----

**Response**

channel 1 status			channel 2 status			W'1
x	0	2	sequence no. (6)	number of read words ( $1 \leq n \leq 13$ )		W'2
0						W'3
data 1						W'4
:						:
data 13						W'16

x	0	1	sequence no. (7)	<b>81h</b>	W1
---	---	---	------------------	------------	----

**Response**

channel 1 status			channel 2 status			W'1
x	0	1	sequence no. (7)	number of read words ( $1 \leq n \leq 13$ )		W'2
13						W'3
data 14						W'4
:						:
data 26						W'16

x	0	2	sequence no. (8)	<b>81h</b>	W1
---	---	---	------------------	------------	----

**Response**

channel 1 status			channel 2 status			W'1
x	0	2	sequence no. (8)	number of read words ( $1 \leq n \leq 13$ )		W'2
13						W'3
data 14						W'4
:						:
data 26						W'16



6.2.4 DETAILS OF FIRST PARAMETER FRAMES BASED UPON OPERATION

**Tag block reading**

number of words to read ( $1 \leq n \leq 7,500$ )	W4
tag address	W5

When the parameters (length and address) are stored in the Command area, the PLC validates the reading by positioning the corresponding bit (and eventually the repetition bit) located in the Command word of the relevant channel.

**Tag block writing**

number of words to write ( $1 \leq n \leq 7,500$ )	W4
tag address	W5
data 1	W6
:	:
data n-3	Wn

For a tag writing operation, the supervisor must inform the data Fields by using the parameter writing command and repeating it as many times as it is required.

When all Command parameters are stored in the Command area, the PLC validates the command by positioning the writing bit (and, eventually, the repetition bit) located in the Command word of the relevant channel.

**Tag blanking**

number of words to write ( $1 \leq n \leq 7,500$ )	W4
tag address	W5
blinking data	x W6

When the parameters (length, address and data) are stored in the Command area, the PLC validates reading by positioning the corresponding bit (and eventually the repetition bit) located in the Command word of the relevant channel.

**Discontinuous reading**

number of words 1	W4
address 1	W5
number of words 2	W6
address 2	W7
number of words 3	W8
address 3	W9
number of words 4	W10
address 4	W11

Number of areas limited to 4.

Total number of words to read  $\leq 2,048$ .

If less than 4 areas must be read, set on 0 the Length area(s) that is (are) not used.

When the parameters (lengths and addresses) are stored in the Command area, the supervisor validates reading by positioning the corresponding bit (and eventually the repetition bit) located in the Command word of the relevant channel.

**Discontinuous writing**

number of words 1	W4
address 1	W5
number of words 2	W6
address 2	W7
number of words 3	W8
address 3	W9
number of words 4	W10
address 4	W11
data 1 <sup>st</sup> block	W12
data 2 <sup>nd</sup> block	W13
data 3 <sup>rd</sup> block	W14
data 4 <sup>th</sup> block	W15

Number of areas limited to 4.

Total number of words to read  $\leq 2,048$ .

If less than 4 areas must be written, set on 0 the Length area(s) that is(are) not used.

No matter what is the number of fields, the start of the first data block is always located after the fourth address field.

When the parameters (lengths, addresses and data) are stored in the Command area, the supervisor validates writing by positioning the corresponding bit (and eventually the repetition bit) located in the Command word of the relevant channel.

**Data copy**

This operation consists of reading the data of a tag on channel 1 and writing them on the next tag showing on channel 2.

Number of words to copy ( $1 \leq n \leq 7\ 500$ )	W4
tag address channel 1 (source)	W5
tag address channel 2 (destination)	W6

The command is only valid if it is sent to channel 1 (channel = 0).

**Data comparison**

This operation consists of reading tag data on channels 1 and 2 and comparing them.

number of words to compare ( $1 \leq n \leq 7\ 500$ )	W4
tag address channel 1	W5
tag address channel 2	W6

The command is only valid if it is sent to channel 1 (channel = 0).

The result of the comparison is provided in the low address word 8000 h:

- 0: irrelevant
- 1: different content
- 2: identical content.

## 6.3 MEMORY MAPPING

### 6.3.1 GENERAL

All the addresses are in words. The BIDP supports internally the absolute addressing.

The BIDP can address 32 Kwords; therefore it can read / write from / to any Balogh tag without limitations (addresses 0 to 7FFF h).

The BIDP RAM is about 30,000 words splitted in four buffers: System, Command, Response and Data.

The addresses range as follows:

areas	size	address	modes
Tag image (virtual memory)	32 Kwords	0 h : 7FFF h	tag addresses
System channel 1	5 words	8000 h : 8004 h	Direct and Recorded
Commands channel 1	7,509 words	8005 h : 9D59 h	Direct and Recorded
System channel 2	5 words	9D5A h : 9D5E h	Direct and Recorded
Commands channel 2	7,509 words	9D5F h : BAB3 h	Direct and Recorded
Response channel 1	3 words	BAB4 h : BAB6 h	Recorded
Data channel 1	7,500 words	BAB7 h : D802 h	Recorded
Response channel 2	3 words	D803 h : D805 h	Recorded
Data channel 2	7,500 words	D806 h : F551 h	Recorded

The detailed content of each area is as follows.

### 6.3.2 SYSTEM AREA

address	content	access
8000h / 9D5Ah	execution byte   comparison result (ch. 1)	R/W
8001h / 9D5Bh	tag counter (ch. 1/ ch. 2)	R/W
8002h / 9D5Ch	command word (ch. 1/ ch. 2)	R/W
8003h / 9D5Dh	tag dialogue error counter (ch. 1/ ch. 2)	R/W
8004h / 9D5Eh	last tag dialogue error (ch. 1/ ch. 2)	R/W

### 6.3.3 COMMAND AREA

address	content	access
8005h / 9D5Fh	current code (ch. 1/ ch. 2)	R/W
8006h / 9D60h	length 1 (ch. 1/ ch. 2)	R/W
8007h / 9D61h	address 1 (ch. 1/ ch. 2)	R/W
8008h / 9D62h	length 2 (ch. 1/ ch. 2) or data 1*	R/W
8009h / 9D63h	address 2 (ch. 1/ ch. 2) or data 2	R/W
:	:	R/W
800Ch / 9D66h	length 4 (ch. 1/ ch. 2)	R/W
800Dh / 9D67h	address 4 (ch. 1/ ch. 2)	R/W
800Eh / 9D68h	data 1 (ch. 1/ ch. 2)**	R/W
:	:	R/W
9D59h/ BAB3h	data 7,500 (ch. 1/ ch. 2)	R/W

\* first data for block writing

\*\* first data for discontinuous writing.

### 6.3.4 RESPONSE AREA

address ch. 1	address ch. 2	content	access
BAB4 h	D803 h	command code	read only
BAB5 h	D804 h	error code	
BAB6 h	D805 h	number of words read/written	

### 6.3.5 DATA AREA

address ch. 1	address ch. 2	content	access
BAB7 h	D806 h	data 1	read only
:	:	:	
D802 h	F551 h	data 7500	

APPENDIX 1 – TAG ADDRESSING

Tag type	Memory type	Capacity (bytes)	address in bytes	address in words
OF	EEPROM	7	0 - 6 h	0 - 3 h
OL	EEPROM	2	0 - 1 h	0 h
OMA (D)	internal FRAM	64	800 h - 83F h	400 h - 41F h
OMA (D) 2K	external FRAM internal FRAM	2 K 64	0 - 7FF h 800 h - 83F h	0 - 3FF h 400 h - 41F h
OMA (D) 8K	internal FRAM external FRAM	64 8 K	800 h - 83F h 2000 h - 3FFF h	400 h - 41F h 1000 h - 1FFF h
OMX 931	FRAM	8 K	0 - 1FFF h	0 - FFF h
OMX 931	FRAM	32 K	0 - 7FFF h	0 - 3FFF h
OIR, OIB	RAM	64 K	0 - FFFD h	0 - 7FFE h
GIE	FRAM	512	0 - 1FF h	0 - FF h
GIE	FRAM	2 K	0 - 7FF h	0 - 3FF h
GIE	FRAM	8 K	2000 h - 3FFF h	1000 h - 1FFF h
FE or FA	EEPROM	32 bits / 5	0 - 4 h	0 - 2 h
EE or EA	EEPROM	64 accessible per block of 4	0 - 3F h (reading) C h - 4C h (writing)	0 - 1F h (reading) 6 h - 25 h (writing)
TAI	EEPROM	48 accessible per block of 4	10 h - 2F h multiple of 4	8 h - 1E h and even
TAF	FRAM	2 k access per block of 8	0 - 7CF h multiple of 8	0 - 3E6 h multiple of 4

APPENDIX 2 – GSD FILE

The BAL\_077F.GSD is a configuration file used to configure the dialogue between the Profibus DP coupler and the BIDP;

**GSD file:**

```

;
;
#Profibus_DP
Vendor_Name = « BALOGH »
Model_Name = « BIDP170 »
Revision = « Revision 1 »
Ident_Number = 0x077F
Protocol_Ident = 0
Station_Type = 0
FMS_supp = 0
Hardware_Release = "REV 1.1"
Software_Release = "REV 1.1"
9.6_supp = 1
19.2_supp = 1
93.75_supp = 1
187.5_supp = 1
500_supp = 1
1.5M_supp = 1
3M_supp=1
6M_supp=1
12M_supp=1
MaxTsdr_9.6 = 60
MaxTsdr_19.2 = 60
MaxTsdr_93.75 = 60
MaxTsdr_187.5 = 60
MaxTsdr_500 = 100
MaxTsdr_1.5M = 150
MaxTsdr_3M = 250
MaxTsdr_6M = 450
MaxTsdr_12M = 800
Redundancy = 0
Repeater_Ctrl_Sig = 0
24V_Pins = 0
Bitmap_Device="BIDP170"
Slave_Family=11@TdF@BALOGH
;
;--Slave keys
;
Freeze_Mode_supp = 1
Sync_Mode_supp = 1
Auto_Baud_supp = 1

```

```
Set_Slave_Add_supp = 0
Min_Slave_Intervall = 1
Modular_Station = 1
Max_Module = 1
Max_Input_Len = 192
Max_Output_Len = 192
Max_Data_Len = 384
Max_Diag_Data_Len = 6
;
;
;
Module="16 words In / 16 Words Out" 0xdf,0xef
EndModule
Module="4 words In / 4 Words Out" 0x97,0xa7
EndModule
Module="8 words In / 8 Words Out" 0x9f,0xaf
EndModule
Module="32 words In / 32 Words Out" 0xdf,0xdf,0xef,0xef
EndModule
Module="48 words In / 48 Words Out" 0xdf,0xdf,0xdf,0xef,0xef,0xef
EndModule
Module="64 words In / 64 Words Out" 0xdf,0xdf,0xdf,0xdf,0xef,0xef,0xef,0xef
EndModule
Module="80 words In / 80 Words Out"
0xdf,0xdf,0xdf,0xdf,0xdf,0xdf,0xef,0xef,0xef,0xef,0xef
EndModule
Module="96 words In / 96 Words Out"
0xdf,0xdf,0xdf,0xdf,0xdf,0xdf,0xdf,0xef,0xef,0xef,0xef,0xef,0xef
EndModule
;
```

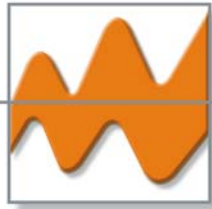

## BIDP 170(M) Connection accessories

### IDENTIFICATION SYSTEMS

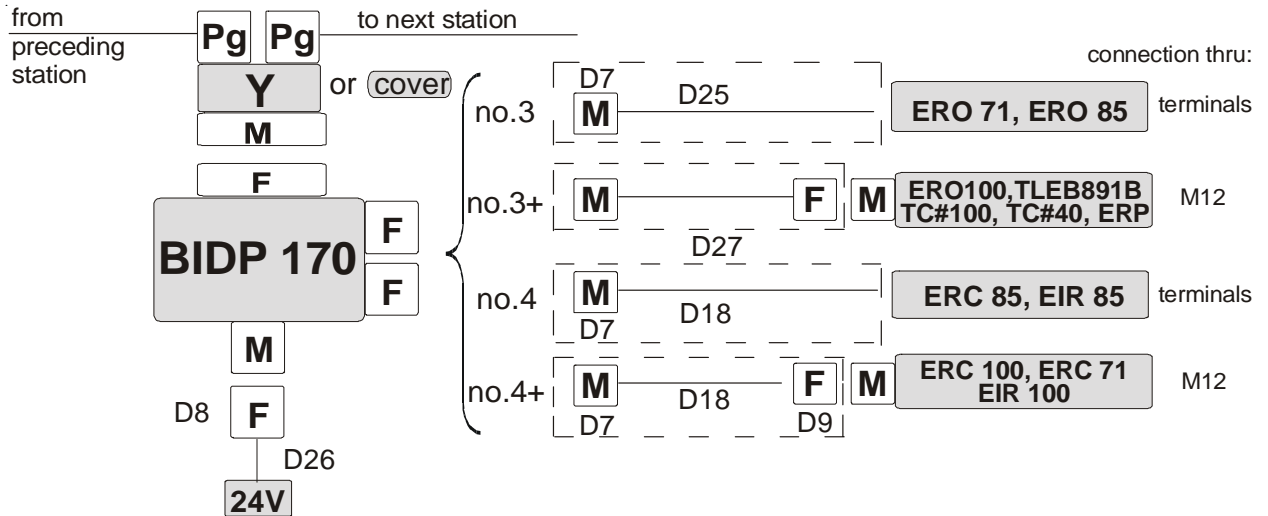

### Characteristics

Mark	Item	Dimension	Description	Outer jacket	Part-No.
D7	cable connector	M12	5 pins, PG9 output for Ø9 max., shieldable		202 237
D8	cable connector	M12	4 pins, PG9 output for Ø9 max.		202 239
D9	cable connector	M12	5 pins, PG9 output for Ø9 max., shieldable		202 274
D17	Profibus cable	5 m	2 leads, shielded	purple PVC	202 261
D18	ERC / EIR cable	Ø 8	2 x 2 x 0.22 <sup>2</sup> , Ø 8, screened pairs with drain	gray PVC	202 238
D25	ERO cable	5 m, Ø 6	4 x 0.5 <sup>2</sup> , Ø 6, braid shield	gray PVC	201 282
D26	power cable	5 m, Ø 6.8	2 x 1 <sup>2</sup>	gray PVC	202 240
D27	ERO / TC# cord	5 m, Ø 6	5 x 0.34 <sup>2</sup> , braid shield, two M12 overmolded	black PUR	
Y	130°-angled Y-tap		SUB-D9 plug, two PG11 stuffing boxes		202 911
cover	plug	Ø 6 x 17	hollow cap		

### Reference numbers for orders

	Item	Content	Reference no.
Conn.	202 911	Y	495XXB4469
C O R D S E T S	no.3	5 m - long cord D7, D25	495XXB4347
	double no.3	two 5 m - long cords D7, D25	495XXB4341
	no.3+	5 m - long cord D27	495XXB4512
	no.4	5 m - long cord D7, D18	495XXB4352
	double no.4	two 5 m - long cords D7, D18	495XXB4342
	no.4+	15 m - long cord D7, D9, D18	495XXB4361

### Correspondence

between pin no. and wire colour for R/W heads connected by terminals

V: 24V, S : output, E : input, O : 0V

BIDP R/W heads →	ERO / ERP		ERC / EIR	
pin no.	description	colour	description	colour
1	V	brown	V	red
2	S	gren	S	black
3	E	yellow	E	black
4	O	white	O	white



# NETWORK CONNECTION

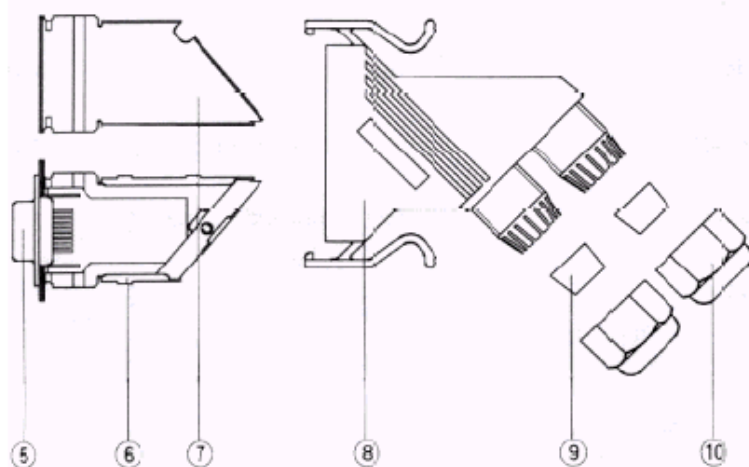

- ⑤ D-SUB contact insert
- ⑥ EMC inner sleeve, lower shell
- ⑦ EMC inner sleeve, upper shell
- ⑧ Sleeve housing
- ⑨ Cable gasket
- ⑩ Pressure nut

## Assembly the sleeve housing ⑧:

- slide the pressure nuts ⑩ and seals ⑨ over the cables (the seals pointing outwards), slide the cables into the sleeve housing ⑧; at the network end close the outgoing cable opening by inserting the cover cap (head outside) and tightening the pressure nut thoroughly,

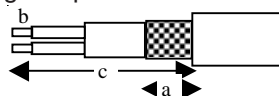

- connect the cables internally:
  - remove the lower (resp. upper) cable sheath to length  $c = 25$  (resp.  $38$ ) mm
  - cut the cable shield to length  $a = 11$  (resp.  $16$ ) mm
  - strip the cores to length  $b = 5$  mm
  - connect the cores at the terminals of the circuit attached to ⑤ in accordance with the table:

Marking	RS-485 signal	Cable	Wire colour
1A	A	incoming	green
1B	B	incoming	red
2A	A	outgoing	green
2B	B	outgoing	red

- assembly the EMC inner sleeve:
  - position contact insert ⑤ in the lower shell ⑥ of the EMC inner sleeve ⑥ + ⑦,
  - screw cable shield with the clamping bar,
  - snap on upper shell ⑦ checking that the contact insert and the cables are correctly positioned,
- push the contact insert back into the sleeve housing and fix using self-tapping screws,
- push the seals ⑨ into the screw connections as far as they will go and tighten pressure nuts ⑩.

**Configure the switch:** open the closing cap and move the switch to the desired position using a suitable tool, in accordance with the table:

Position	Marking	Terminating & bias resistors
to BIDP	ON	active
to network	OFF	not connected

Fasten the closing cap with due care to guarantee that it is tightly sealed.

**Secure** the sleeve housing on the fixed connector (“push-pull”).

**Note:** 5VDC is supplied by BIDP to energize the network terminating resistor.